



Welcome to Kent Cams

Choosing the right camshaft can be one of the most problematic decisions you will have to make when preparing your engine, however you can be assured that with 'Kent Cams' you are in the company of some of the most prestigious names in motorsport engine building.

Our UK based manufacturing facility is Europe's most up to date*, this coupled with our experience in cam profile grinding which spans 5 decades gives you the confidence that you have made the right camshaft choice for your engine.

*We are the only UK based manufacturer to invest in a new bespoke CNC and believe this to be the most up to date machine available to the aftermarket in Europe.



More than just camshafts

Although, as our name suggests we are primarily camshaft manufacturers, we also offer a vast range of complimentary components to ensure trouble free and reliable running of your engine.

From in house manufactured adjustable cam pulleys, spring retainers and cam followers to being major stockists of both 'ARP' bolts and 'Cometic' multi-layer gaskets we produce and hold stock of the largest range of ancillary valve train components in the UK.

Valve springs, Cam followers, Slotted Gears, Adjustable cam pulleys, Valve spring retainers, Multi layer Cylinder head gaskets, ARP Engine fasteners.....

The difference is in the detail..

If you really want to know, here are some of the important differences between us and other manufacturers:

Bespoke multi-angle twin spindle CNC cam grinding facility.

35mm CNC negative radius profile grinding.

Constant surface speed CBN grinding wheels.

Marposs 3 dimensional 'C' and 'Z' axis positioning probe.

Microphonic wheel dressing with wheel size profile compensation.

CNC Isolation room ensuring perfect grinding.

'Lotus Engineering' concept valve train cam design suite.

Over 30 years dedicated solely to performance cam design and grinding.

On site CNC machine shop dedicated to support our grinding centre.

The Complete package

When we produce a camshaft or profile for your engine we also offer the necessary components to enable correct and reliable installation – this is a principle not all manufacturers subscribe to.....

Our catalogue camshafts have been designed to be used in conjunction with components manufactured and available from Kent Cams.

We only offer camshafts or profiles when we can ensure full compatability with either OE parts or our bespoke components.

For the latest technical developments visit: kentcams.com

PERFORMANCE AUTOMOTIVE CAMSHAFT KITS

PERFORMANCE AUTOMOTIVE CAMSHAFTS

VEHICLE	SPECIFICATION	PART NO	NOTE
AUDI A3/A4 1.6 1.8 Hydraulic	SPORTS R	GS2HK	D
AUDI 80 2.0 8V Hydraulic	SPORTS INJ	GS22HK	D
BMW 318i M40 non roller type	SPORTS INJ	BM42K	D
BMW 320i 323i 325i M20	SPORTS INJ	BM62K	D
CITROEN SAXO VTS 1.6 16V	SPORTS INJ	PT50K	D
CITROEN C2 1.6 16V	SPORTS INJ	PT47K	D
FORD ESCORT/FIESTA 1300/1600 XFLOW	MILD ROAD	BCF1K	A
FORD ESCORT/FIESTA 1300/1600 XFLOW	FAST ROAD	BCF2K	A
FORD ESCORT/FIESTA 1300/1600 XFLOW	FAST ROAD/RALLY	BCF3K	A
FORD ESCORT/FIESTA 1300/1600 XFLOW	HIGH TORQUE	224K	B
FORD ESCORT/FIESTA 1300/1600 XFLOW	FAST ROAD	234K	B
FORD ESCORT/FIESTA 1300/1600 XFLOW	RALLY	244K	B
FORD ESCORT/FIESTA 1300/1600 XFLOW	FAST ROAD	A2K	A
FORD 2000OHC escort/capri/sierra	SPORTS TORQUE	FR30K	C
FORD 2000OHC escort/capri/sierra	SPORTS	FR31K	C
FORD 2000OHC escort/capri/sierra	SPORTS R	FR32K	C
FORD 2000OHC escort/capri/sierra	FAST ROAD/RALLY	FR33K	C
FORD 2000OHC escort/capri/sierra	SPORTS INJ	FR34K	C
FORD 2000OHC escort/capri/sierra	COMPETITION	RL30K	C
FORD 2000OHC escort/capri/sierra	ROAD/RALLY	RL31K	C
FORD 2000OHC escort/capri/sierra	RALLY	RL32K	C
FORD 2000OHC escort/capri/sierra	COMPETITION	RC31K	C
FORD 2000OHC escort/capri/sierra	NEW ULTIMATE ROAD	GTS1K	C
FORD 2000OHC escort/capri/sierra	LIGHTNING ROD	GTS2K	C
FORD 2000OHC escort/capri/sierra	RALLY	GTS3K	C
FORD 2000OHC escort/capri/sierra	RALLY	GTS4K	C
FORD 2000OHC escort/capri/sierra	HOT ROD	GTS5K	C
FORD 2000OHC escort/capri/sierra	HOT ROD	GTS6K	C
FORD 2000OHC escort/capri/sierra	F2 STOCK CAR	GTS7K	C
FORD 2000OHC escort/capri/sierra	F2 STOCK CAR	GTS8K	C
FORD 2000OHC escort/capri/sierra	COMPETITION	HTIK	C
FORD 2000OHC escort/capri/sierra	NEW COMPETITION	HT1EK	C
FORD 2000OHC escort/capri/sierra	COMPETITION	GP1K	C
FORD 2000OHC escort/capri/sierra	COMPETITION	RC1K	C
FORD RS2000 DOHC 16V Hydraulic	SPORTS INJ	RS2001K	D
FORD CVH 1.3 1.4 1.6 Hydraulic	SPORTS	CVH21K	E
FORD CVH 1.3 1.4 1.6 Hydraulic	SPORTS R	CVH22K	E
FORD CVH 1.3 1.4 1.6 Hydraulic	SPORTS INJ	CVH32K	E
FORD CVH 1.3 1.4 1.6 Hydraulic	COMPETITION	CVH33K	E
FORD ESCORT/FIESTA RS TURBO	SPORTS	CVH31K	E
FORD ESCORT/FIESTA RS TURBO	SPORTS R	CVH34K	E
FORD ESCORT/FIESTA RS TURBO	SPORTS R	CVH35K	E
FORD ESCORT/FIESTA RS TURBO	COMPETITION	CVH37K	E
FORD COSWORTH 16V TURBO HYD	SPORTS	BD10K	D
FORD ZETEC 16V 1.6 HYD	SPORTS	FZ1601K	D

VEHICLE	SPECIFICATION	PART NO	NOTE
FORD ZETEC 16V 1.8 up to 1998	SPORTS	FZ1801K	D
FORD ZETEC 16V 1.8 up to 1998	SPORTS R	FZ1802K	D
FORD ZETEC 16V 2.0 up to 1998	SPORTS	FZ2001K	D
FORD CAPRI/GRANADA 3.0L V6 ESSEX	MILD ROAD	V61K	A
FORD CAPRI/GRANADA 3.0L V6 ESSEX	FAST ROAD/RALLY	V62K	A
FORD CAPRI/GRANADA 3.0L V6 ESSEX	FAST ROAD	V63K	A
FORD SIERRA/CAPRI/GRANADA 2.3 2.8 V6	MILD ROAD	V6T1K	A
FORD SIERRA/CAPRI/GRANADA 2.3 2.8 V6	SPORTS	V6T2K	A
FORD SIERRA/CAPRI/GRANADA 2.3 2.8 V6	SPORTS R	V6T3K	A
FORD SIERRA/CAPRI/GRANADA 2.8 V6 INJ	SPORTS INJ	V6T21K	A
FORD SIERRA/CAPRI/GRANADA 2.8 V6 INJ	SPORTS R	V6T31K	A
FORD SIERRA/SCORPIO 2.9 V6 INJ MECH	SPORTS	V6T45K	A
FORD FIESTA 1.1 1.3 HCS ENGINE	SPORTS	FST11K	A
FORD KA1.3 OHV	SPORTS	KA11K	A
LOTUS ELISE 1.8 16V	SPORTS	LE1811K	D
PEUGEOT 205/309/405 1.6/1.9 GTI 8V	SPORTS INJ	PT36K	D
PEUGEOT 306 XSI 2.0 8V	SPORTS INJ	PT46K	D
PEUGEOT 405 MI16 16V UP TO 1992	SPORTS INJ	PT1601K	D
PEUGEOT 306 S16 2.0 16V 1993>96	SPORTS INJ	PT2001K	D
PEUGEOT 206 1.6 20V	SPORTS INJ	PT47K	D
PEUGEOT 106 1.6 GTI 16V	SPORTS INJ	PT50K	D
PEUGEOT GTi6 16V/406 COUPE 2.0 16V	SPORTS INJ	PT80K	D
RENAULT CLIO/MEGANE 1.8 16V	SPORTS INJ	RN1601K	D
RENAULT CLIO/MEGANE 2.0 16V	SPORTS INJ	RN2002K	D
ROVER A SERIES 850/100/1100/1275/1300	HIGH TORQUE	MD246K	A
ROVER A SERIES 850/100/1100/1275/1300	MILD ROAD	MD256K	A
ROVER A SERIES 850/100/1100/1275/1300	FAST ROAD	MD266K	A
ROVER A SERIES INJECTION	SPORTS INJ	MD274K	A
ROVER A SERIES 850/100/1100/1275/1300	FAST ROAD/RALLY	MD276K	A
ROVER A SERIES 850/100/1100/1275/1300	RALLY	MD286K	A
ROVER B SERIES 1600/1800	MILD ROAD	714K	F
ROVER B SERIES 1600/1800	FAST ROAD	715K	F
ROVER B SERIES 1600/1800	RALLY	716K	F
ROVER B SERIES 1600/1800	FAST ROAD	717K	F
ROVER K SERIES 1.4 16V	SPORTS INJ	RK1411K	D
ROVER K SERIES 1.6 16V	SPORTS INJ	RK1611K	D
ROVER K SERIES 1.8 16V	SPORTS INJ	RK1811K	D
ROVER V8 3.5/3.9/4.6/5.0 HYD	SPORTS TORQUE	H180K	A
ROVER V8 3.5/3.9/4.6/5.0 HYD	MILD ROAD	H200K	A
ROVER V8 3.5/3.9/4.6/5.0 HYD	FAST ROAD	H214K	F
ROVER V8 3.5/3.9/4.6/5.0 HYD	FAST ROAD	H218K	A
ROVER V8 3.5/3.9/4.6/5.0 HYD	COMPETITION	H224K	F
SEAT CUPRA SPORT/TOLEDO 2.0 8V	SPORTS INJ	SE1HK	D
SEAT CUPRA SPORT/TOLEDO 2.0 8V	SPORTS R	SE2HK	D
SEAT IBIZA/CORDOBA/TOLEDO 2.0 16V	SPORTS INJ	SE2001K	D

VEHICLE	SPECIFICATION	PART NO	NOTE
TRIUMPH 1200/1300/1500 4 CYL	HIGH TORQUE	TH12K	A
TRIUMPH 1200/1300/1500 4 CYL	FAST ROAD	TH2K	A
TRIUMPH 1200/1300/1500 4 CYL	RALLY	TH3K	A
TRIUMPH 1200/1300/1500 4 CYL	FAST ROAD	TH5K	A
TRIUMPH 2000/2.5 6 CYL	HIGH TORQUE	TH12-6K	A
TRIUMPH 2000/2.5 6 CYL	FAST ROAD	TH2-6K	A
VAUXHALL ASTRA/NOVA 1.2/1.3 8V	SPORTS	AST11K	D
VAUXHALL ASTRA/NOVA 1.2/1.3 8V	SPORTS	AST1K	F
VAUXHALL ASTRA/NOVA 1.2/1.3 8V	SPORTS R	AST2K	F
VAUXHALL ASTRA/NOVA 1.2/1.3 8V	COMPETITION	AST3K	F
VAUXHALL CORSA 1.4/1.6 8V 1989 ON	SPORTS INJ	NVO51K	D
VAUXHALL CORSA 1.4/1.6 8V 1989 ON	SPORTS R	NVO52K	D
VAUXHALL CORSA 1.4/1.6 8V 1989 ON	SPORTS R	NVO61K	F
VAUXHALL CORSA 1.4/1.6 8V 1989 ON	SPORTS INJ	NOV62K	F
VAUXHALL CORSA 1.4/1.6 8V 1989 ON	COMPETITION	NVO63K	F
VAUXHALL CORSA 1.4 16V	SPORTS INJ	COR1601K	D
VAUXHALL CORSA 1.6 16V	SPORTS INJ	COR1602K	D
VAUXHALL VECTRA/CALIBRA 2.0 8V	SPORTS INJ	AST52K	D
VAUXHALL VECTRA/CALIBRA 2.0 8V	SPORTS INJ	AST14K	A
VAUXHALL VECTRA/CALIBRA 2.0 8V	SPORTS R	AST15K	A
VAUXHALL VECTRA/CALIBRA 2.0 8V	COMPETITION	AST16K	A
VAUXHALL ASTRA 2.0 16V UP TO 1992	SPORTS INJ	AST1612K	D
VAUXHALL ASTRA 2.0 16V UP TO 1992	COMPETITION	AST1603K	F
VAUXHALL ASTRA 2.0 16V UP TO 1992	NEW COMPETITION	AST1608K	F
VAUXHALL ASTRA 2.0 16V UP TO 1992	NEW COMPETITION	AST1613K	F
VAUXHALL ASTRA 2.0 16V UP TO 1992	NEW COMPETITION	AST1623K	F
VAUXHALL MANTA 1.9/2.0 RWD CIH ENG	SPORTS	OP214K	A
VAUXHALL VECTRA 1.8/2.0/2.2 ECOTEC	SPORTS INJ	EC2001K	D
VW GOLF/SCIROCCO1.6/1.8 8V HYD	SPORTS INJ	GS1HK	D
VW GOLF/SCIROCCO1.6/1.8 8V HYD	SPORTS R	GS2HK	D
VW GOLF/CORRADO 2.0 8V HYD	SPORTS INJ	GS22HK	D
VW GOLF G60 1.8 8V HYD	SPORTS INJ	GS4HK	D
VW GOLF/CORRADO VR6	SPORTS INJ	VR602K	D
VW GOLF 1.8/2.0 16V	SPORTS INJ	GF1602RK	D

NOTE: Kits Include

A	B	C	D	E	F
Camshaft	Camshaft	Camshaft	Camshaft	Camshaft	Camshaft
Followers	Followers	Followers	Followers	Followers	Followers
Valve Springs	Valve Springs	Valve Springs	Valve Springs	Valve Springs	Valve Springs
Cam Lube	Modified	Ball Studs	Cam Lube	Stem Seals	Modified
	Retainers	Spray Bar		Cam Lube	Retainers
	Stem Seals	Stem Seals			Cam Lube
	Cam Lube	Cam Lube			



Selecting the right camshaft?

Whether you want to out accelerate the latest performance car or are looking for an improvement in the performance of your car, a 'Sports Cam Kit' is a definite necessity.

No other single modification will result in a greater increase in performance.

Picking the right Cam Kit for your car is as easy as **1, 2, 3.**

1 'Sports' Fast Road Cams & Kits

These Cam Kits are designed utilising the latest in cam design technology, low overlap and minimal duration to help create a cam package that is unbeatable when installed into a standard production road car. Improves mid-range and upto **+22bhp gains in power** (depending on model). No other modifications are necessary to ensure straightforward installation and trouble free smooth running.

2 'Sports 'R' Fast Road/Rally Cams & Kits

The 'Sports 'R' Cam Kit' is designed specifically for the spirited driver. Utilising maximum valve acceleration technology to design cams for cars that have the benefit of other modifications. This cam range is capable of achieving **+30bhp gains in power**. We recommend the use of a performance exhaust, air filter and chip with this range of cams.

3 Competition' Rally Cams & Kits

This range of cam kits are specifically designed for motorsport/competition use, and are therefore not recommended for use on the public highway. Please refer to the main catalogue for particular specifications and applications.

PART No.	APPLICATION <small>See page 3 for key to Camshaft descriptions</small>	POWER BAND	CAM LIFT INLET/EXHAUST	VALVE LIFT INLET/EXHAUST	DURATION INLET/EXHAUST	TIMING FIGURES	FULL LIFT POSITION INLET/EXHAUST	V/CLEARANCE INLET/EXHAUST	VALVE LIFT INLET	@ TDC EXHAUST
----------	---	------------	---------------------------	-----------------------------	---------------------------	-------------------	-------------------------------------	------------------------------	---------------------	------------------

ALFA ROMEO 1800/2000 8 Valve Twin Cam Direct acting. Durations quoted at .010" / .25mm checking height

AF1	SPORTS	2000-6000	.415" 10.54mm	.407" 10.33mm	282°	35/67 67/35	106° 106°	.008" 0.20mm	.110" 2.79mm	.096" 2.44mm
AFJK303	RALLY	2500-6500	.474" 12.03mm	.464" 11.78mm	303°	45/78 78/45	106° 106°	.010" 0.25mm	.169" 4.29mm	.163" 4.14mm
AFZL1	RACE	3000-7000	.474" 12.03mm	.464" 11.78mm	320°	58/82 82/58	102° 102°	.010" 0.25mm	.177" 4.50mm	.164" 4.16mm

AUSTIN HEALEY 100-4 Valve lifts are quoted using a theoretical Rocker Ratio of 1.46:1. Duration quoted at .016" / .40mm

AH1	HIGH TORQUE <small>Touring specification</small>	1000-5000	.285" 7.23mm	.400" 10.16mm	252°	18/54 54/18	108°	.016" 0.40mm	.075" 1.90mm	N/A
-----	---	-----------	-----------------	------------------	------	-------------	------	-----------------	-----------------	-----

AUSTIN HEALEY 3000 / MGC 6Cyl Valve lifts are quoted using a theoretical Rocker Ratio of 1.46:1 Durations quoted at .016"/.40mm.

AH2	FAST ROAD <small>Approx. 20bhp at wheels increase</small>	1000-6000	.293" 7.43mm	.411" 10.43mm	278°	33/65 63/31	107°	.016" 0.40mm	.092" 2.33mm	N/A
AH4	RALLY	2000-6500	.323" 8.19mm	.455" 11.57mm	287° 281°	43/67 61/40	100°	.016" 0.40mm	.158" 4.01mm	N/A
AH6	RACE	2500-7000	.323" 8.19mm	.455" 11.57mm	306°	53/73 73/53	100°	.016" 0.40mm	.190" 4.82mm	N/A

BMW MINI ONE-COOPER 1.6 16V Engine Code: W10B16BA Valve lifts quoted using a theoretical Rocker Ratio of 1.55:1. Durations quoted at .004" / .10mm checking height

MINI01	SPORTS	1500-6000	.240" 6.12mm	.228" 5.80mm	.374" 9.5mm	.354" 9.0mm	260°	16/64 64/16	114°	.000" 0.00mm	N/A	N/A
MINI02	SPORTS 'R'	2000-6500	.245" 6.24mm	.228" 5.80mm	.380" 9.67mm	.354" 9.0mm	268° 260°	20/68 64/16	114°	.000" 0.00mm	N/A	N/A

BMW 320i / 323i / 325i M20 Valve lifts quoted using a theoretical Rocker Ratio of 1.56:1 Durations quoted at .010" / .25mm checking height

BM62 <small>Kit Available</small>	SPORTS INJECTION 15 <small>15bhp approx increase Suitable for engines fitted with standard injection and catalyst</small>	2000-6500	.276" 7.01mm	.420" 10.66mm	277°	25/72 72/25	113°	.010" 0.25mm	.055" 1.40mm	N/A
BM63	SPORTS 'R' <small>Modified injection required</small>	2000-6500	.276" 7.01mm	.420" 10.66mm	277°	27/70 70/27	111°	.010" 0.25mm	.062" 1.57mm	N/A
BM64	COMPETITION <small>Modified injection required</small>	3000-8000	.288" 7.31mm	.440" 11.17mm	288°	34/74 74/34	110°	.010" 0.25mm	.110" 2.79mm	N/A

CITROEN SAXO VTR, VSX, SX 1.4 1.6 Non Roller Type Engine Code: TU3M-5M Front bearing size 44.2mm. Not suitable for roller type engines. Valve lifts quoted using a theoretical Rocker Ratio of 1.40:1

PT11 <small>Kit Available</small>	SPORTS INJECTION <small>12bhp approx increase</small>	2000-6000	.276" 7.01mm	.376" 9.81mm	276°	28/68 68/28	110°	.010" 0.25mm	.050" 1.27mm	N/A
--------------------------------------	--	-----------	-----------------	-----------------	------	-------------	------	-----------------	-----------------	-----

CITROEN SAXO VTR 1.4 - 1.6 Roller Type Engine Code: TU3JP-TU5JP Valve lifts quoted using a theoretical Rocker Ratio of 1.75:1 Durations quoted at .010" / .40mm checking height

PT30	SPORTS INJECTION <small>Suitable for 1.4 9bhp approx increase</small>	2000-6500	.230" 5.84mm	.392" 9.95mm	258°	14/64 64/14	115°	.010" 0.25mm	.020" 0.50mm	N/A
PT40	SPORTS INJECTION <small>Suitable for 1.6 11bhp approx increase</small>	2000-6500	.242" 6.14mm	.414" 10.51mm	266°	18/68 68/18	115°	.010" 0.25mm	.030" 0.75mm	N/A

CITROEN SAXO VTS 1.6 16 Valve Engine Code: TU5J4 Duration of hydraulic profiles quoted at 0.004"/.10mm. Mechanical profiles checked at 0.004" / 0.1mm checking height

PT50 <small>Kit Available</small>	SPORTS INJECTION <small>22bhp approx increase with filter kit</small>	1500-6500	.368" 9.34mm	.368" 9.34mm	262°	21/61 61/21	110° 110°	.000" 0.00mm	.035" 0.90mm	.037" 0.95mm
--------------------------------------	--	-----------	-----------------	-----------------	------	-------------	-----------	-----------------	-----------------	-----------------

CITROEN C2 1.6 16V VTR Engine Code: TU5JP4

PT47 <small>Kit Available</small>	SPORTS INJECTION <small>Suitable for 1.6 12bhp approx increase</small>	1500-6500	.336" 8.53mm	.336" 8.53mm	240°	10/50 50/10	110° 110°	.000" 0.00mm	.019" 0.48mm	.014" 0.35mm
--------------------------------------	---	-----------	-----------------	-----------------	------	-------------	-----------	-----------------	-----------------	-----------------

CAM FOLLOWER	VALVE SPRING	CAM BELT	POWER PULLEY	CONROD BOLT	HEADSTUD KIT	OPTIONS & COMMENTS
--------------	--------------	----------	--------------	-------------	--------------	--------------------

CF68	-	-	-	BEB49-8	-	Alfa AFJK303 and AFZL1 are as featured in the Alfa tuning book written by Jim Kartalamakis, they are produced from a steel billet and we can supply CF68 Cam Followers.
CF68	VS42 <small>Double</small>	-	-	BEB49-8	-	
CF68	VS42 <small>Double</small>	-	-	BEB49-8	-	

-	-	-	-	-	-	
---	---	---	---	---	---	--

-	-	-	-	-	-	
-	-	-	-	-	-	
-	-	-	-	-	-	

-	-	-	-	BEB47-8	HSBMW4301	
-	-	-	-	BEB47-8	HSBMW4301	

CF60	-	-	CA39	-	-	
CF60	-	-	CA39	-	-	
CF60	-	-	CA39	-	-	



Durations quoted at 0.010" / 0.25mm checking height

-	-	CB14 CB15	CA31		
---	---	--------------	------	--	--

-	-	-	CA31		
-	-	-	CA31		

CF65	-	CB16	CA72		
------	---	------	------	--	--

CF65	-	CB16	CA72		
------	---	------	------	--	--

PT30 The latest addition to the Saxo range, giving an increase of 9bhp with no other modifications.

PT50 As tested by one of the leading specialists in Citroen/Peugeot tuning. With a pair of camshafts and an air filter kit, the increase was an incredible 22bhp. Achieved by JA Racing.

CB14 CITROEN AXGT 1360cc with AC
CB15 CITROEN AXGT 1360cc without AC

PT40 - This Cam is for the later 1.6 model with Roller Rockers, (silver rocker cover engine) and will give an impressive 11 bhp. Don't give up if you have the earlier engine type with black rocker cover. The PT11 also gives an impressive 12 bhp.

PT47 - Cams for the C2 1.6 16v engine.

These cams give an impressive 12bhp

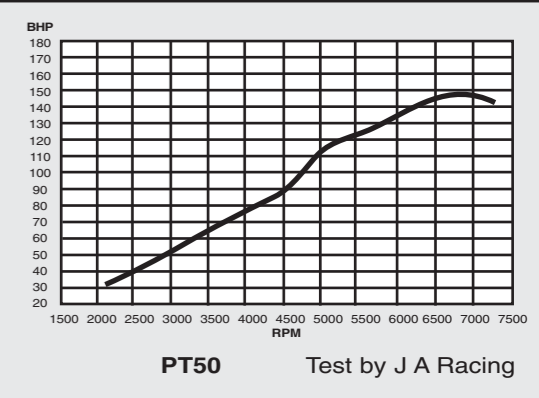

PART No.	APPLICATION See page 3 for key to Camshaft descriptions	POWER BAND	CAM LIFT INLET/EXHAUST	VALVE LIFT INLET/EXHAUST	DURATION INLET/EXHAUST	TIMING FIGURES	INLET TIMING @ FULL LIFT	V/CLEARANCE INLET/EXHAUST	VALVE LIFT INLET	@ TDC EXHAUST
FORD 1300 / 1600 X/FLOW ESCORT Mk1&2 FIESTA Mk1 Valve lifts quoted using a theoretical Rocker Ratio of 1.52:1 Durations quoted at .016" / .40mm checking height										
BCF1 Kit Available	MILD ROAD 6bhp approx over GT Cam	2000-6000	.261" 6.62mm	.384" .378" 9.74mm 9.59mm	270°	26/64 69/21	109°	.012" .018" 0.30mm 0.46mm	.066" 1.67mm	N/A -
BCF2 Kit Available	FAST ROAD 8bhp approx over GT Cam	2000-6500	.261" 6.62mm	.382" .378" 9.69mm 9.59mm	290°	37/73 73/37	108°	.014" .018" 0.36mm 0.46mm	.086" 2.18mm	N/A -
BCF3 Kit Available	FAST ROAD/RALLY 10bhp approx over GT Cam. Maximum cam that will fit without piston mods	2500-7000	.282" 7.15mm	.412" 10.47mm	284°	34/70 70/34	108°	.016" .016" 0.41mm 0.415mm	.098" 2.48mm	N/A -

There is no substitute for this following range of Cams but additional machining will be required. Increase depth of valve cut-outs in piston crown by .100" / 2.54mm

224 Kit Available	HIGH TORQUE Autotest 14bhp approx increase over GT Carb	1000-6500	.287" 7.28mm	.420" .418" 10.66mm 10.61mm	270°	32/58 67/23	103°	.016" .018" 0.41mm 0.46mm	.095" 2.41mm	N/A -
234 Kit Available	FAST ROAD 18bhp approx over GT Carb	2000-7200	.293" 7.43mm	.423" .421" 10.74mm 10.69mm	280°	37/63 73/27	103°	.022" .024" 0.56mm 0.61mm	.112" 2.84mm	N/A -
244 Kit Available	RALLY 115bhp with GT Carb 145bhp with 2 x 40's	3000-8000	.309" 7.84mm	.447" .445" 11.35mm 11.30mm	290°	42/68 78/32	103°	.022" .024" 0.56mm 0.61mm	.138" 3.50mm	N/A -
254	HOT ROD/RACE	4000-8500	.324" 8.22mm	.470" .468" 11.93mm 11.88mm	300°	47/73 83/37	103°	.022" .024" 0.56mm 0.61mm	.169" 4.29mm	N/A -
262	HOT ROD/RACE For use when steel components are prohibited.	4500-8750	.332" 8.43mm	.480" 12.19mm	308°	51/77 87/41	103°	.022" .024" 0.56mm 0.61mm	.185" 4.70mm	N/A -
264	CLUBMANS/FULL RACE	5000-9000	.339" 8.60mm	.493" .491" 12.52mm 12.47mm	310°	52/78 88/42	103°	.022" .024" 0.56mm 0.61mm	.190" 4.82mm	N/A -
272	ULTIMATE RACE CAM	5000-9300	.347" 8.81mm	.505" 12.82mm	314°	54/80 90/44	103°	.022" .024" 0.56mm 0.61mm	.218" 5.55mm	N/A -

ADDITIONAL PROFILES

A2 Kit Available	FAST ROAD	3000-7000	.243" 6.17mm	.349" .347" 8.86mm 8.81mm	286°	35/71 71/35	108°	.020" .022" 0.51mm 0.56mm	.077" 1.95mm	N/A -
A3	RACE	4000-8000	.269" 6.83mm	.388" .386" 9.85mm 9.80mm	310°	47/83 83/47	108°	.020" .022" 0.51mm 0.56mm	.113" 2.87mm	N/A -
A6	RACE	5000-9000	.278" 7.06mm	.404" .402" 10.36mm 10.21mm	304°	46/78 78/46	106°	.018" .020" 0.46mm 0.51mm	.133" 3.38mm	N/A -
A8	RACE	5500-9000	.284" 7.20mm	.413" .411" 10.49mm 10.43mm	312°	56/76 76/56	100°	.018" .020" 0.46mm 0.51mm	.176" 4.47mm	N/A -
A8+	RACE	5000-9000	.327" 8.30mm	.479" .477" 12.16mm 12.11mm	312°	56/76 76/56	100°	.018" .020" 0.46mm 0.51mm	.195" 4.95mm	N/A -
658	RACE	5000-9000	.274" 6.95mm	.396" 10.05mm	320°	60/80 80/60	100°	.020" .020" 0.51mm 0.51mm	.186" 4.73mm	N/A -
747	RACE	4500-8500	.290" 7.36mm	.422" .420" 10.71mm 10.66mm	295°	49/66 66/49	98°	.018" .020" 0.46mm 0.51mm	.180" 4.58mm	N/A -
260	RACE	4000-8000	.316" 8.02mm	.462" .460" 11.73mm 11.68mm	308°	50/78 78/50	104°	.018" .020" 0.46mm 0.51mm	.177" 4.50mm	N/A -
3FY	FAST ROAD	2500-7000	.264" 6.70mm	.389" .387" 9.88mm 9.82mm	276°	30/66 66/30	108°	.012" .014" 0.30mm 0.36mm	.085" 2.16mm	N/A -
IFR4	RACE	4500-8500	.284" 7.20mm	.413" .411" 10.48mm 10.43mm	310°	51/79 79/51	104°	.018" .020" 0.46mm 0.51mm	.160" 4.06mm	N/A -

CAM FOLLOWER	VALVE SPRING	VALVE SPRING RETAINER	POWER PULLEY	CONROD BOLT	FLYWHEEL BOLT	HEADSTUD KIT	MAINSTUD KIT	OPTIONS AND COMMENTS
CF77 CF76	VS5 Single	ST17	S13 S27	BEB08-8 BEB09-8	FB900-6	HSFX48	MSF375	CF77 711M Wide Stem Follower CF76 109E Narrow Stem Follower S13 Lightweight Duplex Power Pulley S27 Simplex Power Pulley ST17 Steel Valve Spring Retainer VR8 Alloy Valve Spring Retainer for - 5/16 Valve Stem VRT05 Titanium Valve Spring Retainer for - 9/32 Valve Stem VRT07 Titanium Valve Spring Retainer for - 5/16 Valve Stem BEB08-8 Conrod Bolts for Steel Rods 3/8 x 1.5ARP BEB09-8 Conrod Bolts for 1.3L/1.6L Rods 3/8 x 1.75ARP S5 100mm Crank V Belt Pulley
CF77 CF76	VS5 Single	ST17	S13 S27	BEB08-8 BEB09-8	FB900-6	HSFX48	MSF375	
CF77 CF76	VS5 Single	ST17	S13 S27	BEB08-8 BEB09-8	FB900-6	HSFX48	MSF375	
CF77 CF76	VS7 Double	ST17 VR8	S13 S27	BEB08-8 BEB09-8	FB900-6	HSFX48	MSF375	
CF77 CF76	VS7 Double	ST17 VR8	S13	BEB08-8 BEB09-8	FB900-6	HSFX48	MSF375	
CF77 CF76	VS39 Double	VRT05 VRT07	S13	BEB08-8 BEB09-8	FB900-6	HSFX48	MSF375	
CF77 CF76	VS39 Double	VRT05 VRT07	S13	BEB08-8 BEB09-8	FB900-6	HSFX48	MSF375	
CF77	VS39 Double	VRT05 VRT07	S13	BEB08-8 BEB09-8	FB900-6	HSFX48	MSF375	
CF77	VS39 Double	VRT05 VRT07	S13	BEB08-8 BEB09-8	FB900-6	HSFX48	MSF375	
CF76 CF77	VS5 Single	ST17	S13 S27	BEB08-8 BEB09-8	FB900-6	HSFX48	MSF375	
CF76 CF77	VS7 Double	ST17 VR8	S13	BEB08-8 BEB09-8	FB900-6	HSFX48	MSF375	
CF76 CF77	VS39 Double	VRT05 VRT07	S13	BEB08-8 BEB09-8	FB900-6	HSFX48	MSF375	
CF76 CF77	VS39 Double	VRT05 VRT07	S13	BEB08-8 BEB09-8	FB900-6	HSFX48	MSF375	
CF76 CF77	VS39 Double	VRT05 VRT07	S13	BEB08-8 BEB09-8	FB900-6	HSFX48	MSF375	
CF76 CF77	VS39 Double	VRT05 VRT07	S13	BEB08-8 BEB09-8	FB900-6	HSFX48	MSF375	
CF76 CF77	VS5 Single	ST17	S13 S27	BEB08-8 BEB09-8	FB900-6	HSFX48	MSF375	
CF76 CF77	VS39 Double	VRT05 VRT07	S13	BEB08-8 BEB09-8	FB900-6	HSFX48	MSF375	

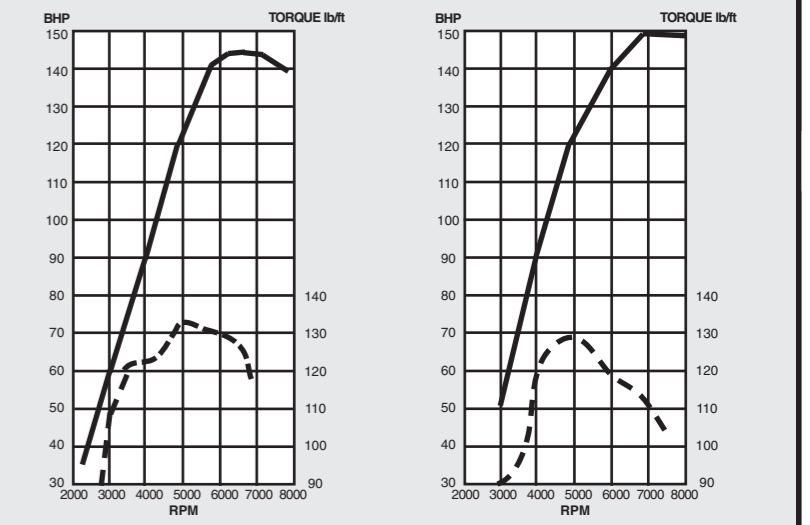

Engine: Ford X/Flow 1830cc Camshaft: 234
 Engine: Ford X/Flow 1700cc Camshaft: 244
 The 234 and 244 cams are probably the most successful cams for the Ford X/Flow engine. These Performance Kits will give your X/Flow a new lease of life.

Performance Ford X/Flow Oil Pumps page 74.

PERFORMANCE AUTOMOTIVE CAMSHAFTS

PERFORMANCE AUTOMOTIVE CAMSHAFTS

PART No.	APPLICATION See page 3 for key to Camshaft descriptions	POWER BAND	CAM LIFT INLET/EXHAUST	VALVE LIFT INLET/EXHAUST	DURATION INLET/EXHAUST	TIMING FIGURES	INLET TIMING @ FULL LIFT	V/CLEARANCE INLET/EXHAUST	VALVE LIFT INLET	@ TDC EXHAUST
----------	--	------------	---------------------------	-----------------------------	---------------------------	-------------------	-----------------------------	------------------------------	---------------------	------------------

FORD 1300 / 1400 / 1600 CVH Hydraulic

Valve lifts quoted using a theoretical Rocker Ratio of 1.65:1 Durations quoted at .004" / .10mm checking height

CVH21 Kit Available	SPORTS <i>8bhp approx increase</i>	1500-6000	.238" 6.04mm	.393" 9.98mm	266° 270°	21/65 67/23	112°	.000" 0.00mm	.038" 0.96mm	N/A -
CVH22 Kit Available	SPORTS 'R' <i>15bhp approx increase</i> Carburettor models	2000-6500	.265" 6.80mm	.437" 11.10mm	274° 278°	28/66 68/30	109°	.000" 0.00mm	.068" 1.72mm	N/A -
CVH32 Kit Available	SPORTS INJECTION <i>14bhp approx increase</i>	1000-6500	.272" .264" 6.90mm 6.70mm	.448" .435" 11.37mm 11.04mm	280° 273°	25/75 63/30	115°	.000" 0.00mm	.036" 0.91mm	N/A -
CVH33 Kit Available	COMPETITION Carburettor models <i>20bhp approx increase</i>	2500-7000	.290" .285" 7.36mm 7.24mm	.478" .470" 12.14mm 11.63mm	290° 285°	36/74 72/33	109°	.000" 0.00mm	.077" 1.95mm	N/A -

FORD 1600 CVH Turbo Hydraulic

Valve lifts quoted using a theoretical Rocker Ratio of 1.65:1 Durations quoted at .004" / .10mm checking height

CVH31 Kit Available	SPORTS <i>15bhp approx increase</i>	1500-6500	.240" 6.12mm	.396" 10.06mm	270°	23/67 67/23	112°	.000" 0.00mm	.038" 0.96mm	N/A -
CVH34 Kit Available	SPORTS 'R' Bayjoo Power <i>20bhp approx increase</i>	1500-7000	.275" .240" 6.98mm 6.12mm	.453" .396" 11.50mm 10.06mm	280° 272°	21/79 75/17	119°	.000" 0.00mm	.026" 0.66mm	N/A -
CVH35 Kit Available	SPORTS 'R' <i>26bhp approx increase</i>	2000-7000	.275" .267" 6.98mm 6.78mm	.453" .440" 11.50mm 11.18mm	276°	20/76 76/20	118°	.000" 0.00mm	.029" 0.73mm	N/A -
CVH36 Kit Available	COMPETITION	2000-7000	.272" .262" 6.90mm 6.65mm	.448" .432" 11.37mm 10.97mm	275° 275°	22/73 73/22	115°	.000" 0.00mm	.037" 0.94mm	N/A -
CVH37 Kit Available	COMPETITION	2500-7000	.296" .290" 7.52mm 7.36mm	.489" .479" 12.42mm 12.16mm	280°	22/78 78/22	118°	.000" 0.00mm	.041" 1.04mm	N/A -

FORD 1300 / 1400 / 1600 CVH / RS1600i Mechanical Profiles

Valve lifts quoted using a theoretical Rocker Ratio of 1.65:1 Durations quoted at .016" / .40mm checking height

CVH26	SPORTS RS1600i direct replacement	1500-6000	.273" 6.93mm	.445" .442" 11.30mm 11.22mm	261°	20/61 61/20	110°	.006" .008" 0.15mm 0.20mm	.055" 1.40mm	N/A -
CVH27	COMPETITION For use with solid followers only	3000-7500	.309" 7.84mm	.487" .485" 12.36mm 12.31mm	290°	42/68 78/32	103°	.022" .024" 0.56mm 0.61mm	.149" 3.78mm	N/A -
CVH28	COMPETITION For use with solid followers only	4000-8000	.324" 8.22mm	.512" .510" 13.00mm 12.95mm	300°	47/73 83/37	103°	.022" .024" 0.56mm 0.61mm	.177" 4.49mm	N/A -

FORD FIESTA 1.1 / 1.3 HCS Engine

Valve lifts quoted using a theoretical Rocker Ratio of 1.52:1 Durations quoted at .016" / .40mm checking height

FST11 Kit Available	SPORTS <i>6bhp approx increase</i>	1500-5500	.220" 5.58mm	.324" .322" 8.22mm 8.18mm	216° 220°	1/35 37/3	107°	.010" .012" 0.25mm 0.30mm	.017" 0.43mm	N/A -
------------------------	--	-----------	------------------------	--	------------------	------------------	-------------	--	------------------------	-----------------

FORD FIESTA 950 / 1100 Not suitable for HCS Engines

Valve lifts quoted using a theoretical Rocker Ratio of 1.52:1 Durations quoted at .016" / .40mm checking height

FST1	MILD ROAD	2000-6000	.261" 6.62mm	.384" .378" 9.74mm 9.59mm	270°	26/64 69/21	109°	.012" .018" 0.30mm 0.46mm	.066" 1.67mm	N/A -
FST2	SPORTS	2500-6500	.241" 6.11mm	.346" .344" 8.78mm 8.73mm	290°	37/73 73/37	108°	.020" .022" 0.51mm 0.56mm	.086" 2.18mm	N/A -
FST3	SPORTS 'R'	2500-7000	.264" 6.70mm	.389" .387" 9.88mm 9.82mm	276°	30/66 66/30	108°	.012" .014" 0.30mm 0.36mm	.085" 2.16mm	N/A -

CAM FOLLOWER	VALVE SPRING	CAM BELT	POWER PULLEY	CONROD BOLT	HEADSTUD KIT	MAINSTUD KIT	OPTIONS AND COMMENTS
--------------	--------------	----------	--------------	-------------	--------------	--------------	----------------------

CF28	VS48 Single	CB01 CBO2	CA18	BEB22-8	HSCVH16	MSCVH16	CVH22 is the most popular performance cam produced for carburation models and will give an increase of 15bhp in a 1.6 XR2, as tested by 'CCC' magazine. CVH32 is the injection version of the CVH22 and will give an increase of 14bhp . OPTIONAL COMPONENTS CB01 Cam Belt 1.3 1980-92 Escort / Orion CB02 Cam Belt 1.6 1984-92 Escort / Orion / RS Turbo S18 Steel Version of Power Pulley HSCVH16 ARP Headstud Kit
CF28	VS48 Single	CB01 CBO2	CA18	BEB22-8	HSCVH16	MSCVH16	
CF28	VS48 Single	CB01 CBO2	CA18	BEB22-8	HSCVH16	MSCVH16	
CF28	VS42 Double	CB01 CBO2	CA18	BEB22-8	HSCVH16	MSCVH16	

CF28	VS22 Single	CB02	CA18	BEB22-8	HSCVH16	MSCVH16	The "RS Turbo" - Everyone's made a cam for this model but Ahmed Bayjoo has had the last word with the new CVH34 producing bhp but most importantly torque in conjunction with the Bayjoo chip "We designed this cam to bridge the gap between the standard cam and the CVH35, it in no way beats the 35 for power but in a 1600cc the torque is phenomenal - spinning wheels in 3rd gear!" <p style="text-align: center;">Ahmed Bayjoo</p>
CF28	VS22 Single	CB02	CA18	BEB22-8	HSCVH16	MSCVH16	
CF28	VS22 Single	CB02	CA18	BEB22-8	HSCVH16	MSCVH16	
CF28	VS42 Double	CB02	CA18	BEB22-8	HSCVH16	MSCVH16	

CF11	VS48 Single	CB01 CBO2	CA18	BEB22-8	HSCVH16	MSCVH16	<div style="text-align: center;"> CVH22 </div>
CF11	VS42 Double	CB01 CBO2	CA18	BEB22-8	HSCVH16	MSCVH16	
CF11	VS42 Double	CB01 CBO2	CA18	BEB22-8	HSCVH16	MSCVH16	
CF49	VS5 Single	-	-	-	-	-	

CF77	VS5 Single	-	-	-	-	-
CF77	VS5 Single	-	-	-	-	-
CF77	VS5 Single	-	-	-	-	-

PART No.	APPLICATION <small>See page 3 for key to Camshaft descriptions</small>	POWER BAND	CAM LIFT INLET/EXHAUST	VALVE LIFT INLET/EXHAUST	DURATION INLET/EXHAUST	TIMING FIGURES	INLET TIMING @ FULL LIFT	V/CLEARANCE INLET/EXHAUST	VALVE LIFT INLET	@ TDC EXHAUST
----------	---	------------	---------------------------	-----------------------------	---------------------------	-------------------	-----------------------------	------------------------------	---------------------	------------------

FORD 2000 OHC Pinto Valve lifts quoted using a theoretical Rocker Ratio of 1.69:1- inlet, 1.65:1 - exhaust. Durations quoted at .010" / .25mm checking height

FR30 <small>Kit Available</small>	SPORTS TORQUE <i>16bhp approx increase</i> <small>Automatic and Towing Suitable for injection</small>	1000-6000	.290" 7.36mm	.482" .469" 12.24mm 11.91mm	260°	20/60 60/20	110°	.008" .010" 0.20mm 0.25mm	.116" 2.95mm	N/A -
FR31 <small>Kit Available</small>	MILD ROAD <i>10bhp approx increase</i>	2000-6500	.259" .269" 6.57mm 6.83mm	.428" .432" 10.87mm 10.97mm	260° 269°	27/53 58/31	103°	.010" .012" 0.25mm 0.30mm	.068" 1.73mm	N/A -
FR32 <small>Kit Available</small>	FAST ROAD <i>16bhp approx increase</i>	2500-7000	.275" 6.98mm	.455" .442" 11.56mm 11.22mm	285° 280°	34/71 68/32	108°	.010" .012" 0.25mm 0.30mm	.086" 2.18mm	N/A -
FR33 <small>Kit Available</small>	FAST ROAD / RALLY <i>22bhp approx increase</i> <small>Ultimate for modified road engine</small>	3000-7500	.280" 7.11mm	.463" .450" 11.76mm 11.43mm	300° 297°	42/78 74/43	108°	.010" .012" 0.25mm 0.30mm	.118" 3.00mm	N/A -
FR34 <small>Kit Available</small>	SPORTS INJECTION	1000-6250	.300" 7.62mm	.499" .485" 12.67mm 12.31mm	263°	22/61 61/22	110°	.008" .010" 0.20mm 0.25mm	.116" 2.95mm	N/A -
RL30 <small>Kit Available</small>	LIGHTNING RODS	2500-7000	.309" .305" 7.84mm 7.74mm	.512" .491" 13.00mm 12.47mm	304° 292°	47/77 71/41	105°	.010" .012" 0.25mm 0.30mm	.135" 3.43mm	N/A -
RL31 <small>Kit Available</small>	ROAD RALLY <small>For use with 40/45/48 DCOE and GP1 (Stage 3) head</small>	2750-7500	.307" 7.79mm	.509" .495" 12.92mm 12.57mm	304° 297°	46/78 74/43	106°	.010" .012" 0.25mm 0.30mm	.131" 3.33mm	N/A -
RL32 <small>Kit Available</small>	RALLY	3000-7750	.313" 7.95mm	.521" .506" 13.23mm 12.85mm	322°	61/81 81/61	100°	.008" .010" 0.20mm 0.25mm	.150" 3.81mm	N/A -
RC31 <small>Kit Available</small>	RACE	4000-8500	.335" 8.50mm	.554" .539" 14.07mm 13.69mm	323° 336°	53/90 96/60	108°	.012" .014" 0.30mm 0.36mm	.182" 4.62mm	N/A -

FORD 2000 OHC Pinto Motorsport Series Valve lifts quoted using a theoretical Rocker Ratio of 1.69:1-Inlet, 1.65:1- Exhaust Durations quoted at .010" / .25mm checking height

GTS1 <small>Kit Available</small>	ULTIMATE ROAD NEW	2250-7000	.303" 7.7mm	.504" .492" 12.8mm 12.5mm	294°	39/75 75/39	108°	.008" .020" 0.010mm 0.25mm	.110" 2.8mm	N/A -
GTS2 <small>Kit Available</small>	LIGHTNING ROD	3000-7250	.312" 7.92mm	.519" .505" 13.18mm 12.82mm	300°	40/80 80/40	110°	.008" .010" 0.20mm 0.25mm	.136" 3.45mm	N/A -
GTS3 <small>Kit Available</small>	LOOSE SURFACE <small>with wide power band for single gear use</small>	3250-8000	.314" 7.97mm	.520" .508" 13.20mm 12.90mm	312°	53/79 89/43	103°	.010" .010" 0.25mm 0.25mm	.160" 4.06mm	N/A -
GTS4 <small>Kit Available</small>	TARMAC RALLY	3750-8250	.325" 8.25mm	.539" .526" 13.69mm 13.36mm	312°	53/79 89/43	106°	.010" .010" 0.25mm 0.25mm	.185" 4.70mm	N/A -
GTS5 <small>Kit Available</small>	HOT ROD LONG TRACK	4000-8000	.314" 7.97mm	.520" .508" 13.20mm 12.90mm	300°	44/76 76/44	106°	.010" .010" 0.25mm 0.25mm	.136" 3.45mm	N/A -
GTS6 <small>Kit Available</small>	HOT ROD SHORT TRACK/SUPER STOCK	4000-8000	.325" 8.25mm	.539" .526" 13.69mm 13.36mm	296°	40/76 74/42	108°	.010" .010" 0.25mm 0.25mm	.148" 3.76mm	N/A -
GTS7 <small>Kit Available</small>	ULTIMATE F2 STOCK CAR <small>Valve springs may need replacing after 30 meetings</small>	3750-8250	.322" 8.17mm	.534" .521" 13.56mm 13.23mm	310° 310°	47/83 89/41	108°	.010" .010" 0.25mm 0.25mm	.193" 4.90mm	N/A -
GTS8 <small>Kit Available</small>	F2 STOCK CAR	3500-8000	.291" 7.39mm	.482" .470" 12.24mm 11.93mm	312° 312°	50/82 86/46	106°	.010" .010" 0.25mm 0.25mm	.175" 4.44mm	N/A -
HT1 <small>Kit Available</small>	COMPETITION	3000-8000	.293" .288" 7.44mm 7.31mm	.485" .465" 12.32mm 11.81mm	314° 308°	51/83 80/48	106°	.010" .010" 0.25mm 0.25mm	.166" 4.21mm	N/A -
HT1E <small>Kit Available</small>	COMPETITION NEW	3000-7750	.318" .315" 8.10mm 8.00mm	.530" .510" 13.46mm 12.95mm	316° 300°	54/82 74/46	104°	.008" .010" 0.20mm 0.25mm	.210" 5.33mm	N/A -

FORD 2000 OHC Pinto Additional Profiles Valve lifts quoted using a theoretical Rocker Ratio of 1.69:1- inlet, 1.65:1 - exhaust. Durations quoted at .010" / .25mm checking height

GP1	RACE	3000-7500	.296" 7.51mm	.492" .478" 12.49mm 12.14mm	313° 311°	48/85 84/47	108°	.008" .010" 0.20mm 0.25mm	.135" 3.43mm	N/A -
RC1	RACE	3000-7500	.290" 7.36mm	.482" .469" 12.24mm 11.91mm	306°	45/81 81/45	108°	.008" .010" 0.20mm 0.25mm	.140" 3.55mm	N/A -

CAM FOLLOWER	VALVE SPRING	VALVE SPRING RETAINER	CAM BELT	ALLOY POWER PULLEY	ALLOY JACK-SHAFT PULLEY	CONROD BOLT	FLYWHEEL BOLT	HEADSTUD KIT	MAINSTUD KIT	OPTIONAL COMPONENTS
--------------	--------------	-----------------------	----------	--------------------	-------------------------	-------------	---------------	--------------	--------------	---------------------

CF36	VS9 Single	-	CB03	CA11	CA75	BEB60-8	FB1150-6	HSP4201	MSF54	<p>S11 - Steel version of Power Pulley</p> <p>S62 - Extra long ball studs</p> <p>VG04 - Bronze valve guides</p> <p>S49 - Stem seal when valve lift exceeds .430"/10.92mm</p> <p>S81 - Uprated follower Retaining clips</p> <p>Performance OHC Oil Pumps page 72</p> <p>GTS6,7,8 if double valve springs are permitted - use VS42</p> <p>After extensive research and development in conjunction with HT Racing and Vulcan Engineering a new HT1 has arrived - drawing on all that was great about the original, the new HT1e produces 10lb/ft more torque than the HT1, the same maximum power is produced 300rpm lower at 7000rpm with an average increase of 10bhp from 4000-7000 over the HT1</p> <div style="text-align: center;"> <p>HT1e</p> </div> <p>Other profiles available: FR1, FR2, FR21, FR22, RC21, RL1, RL2, RL21, RL22, WR40</p> <p>See specifications at kentcams.com</p>
CF36	VS9 Single	-	CB03	CA11	CA75	BEB60-8	FB1150-6	HSP4201	MSF54	
CF36	VS9 Single	-	CB03	CA11	CA75	BEB60-8	FB1150-6	HSP4201	MSF54	
CF36	VS41 Single	-	CB03	CA11	CA75	BEB60-8	FB1150-6	HSP4201	MSF54	
CF36	VS9 Single	-	CB03	CA11	CA75	BEB60-8	FB1150-6	HSP4201	MSF54	
CF36	VS41 Single	-	CB03	CA11	CA75	BEB60-8	FB1150-6	HSP4201	MSF54	
CF36	VS42 Double	VR5	CB03	CA11	CA75	BEB60-8	FB1150-6	HSP4201	MSF54	
CF36	VS42 Double	VR5	CB03	CA11	CA75	BEB60-8	FB1150-6	HSP4201	MSF54	
CF36	VS42 Double	VR5	CB03	CA11	CA75	BEB60-8	FB1150-6	HSP4201	MSF54	
CF36	VS41 Single	-	CB03	CA11	CA75	BEB60-8	FB1150-6	HSP4201	MSF54	
CF36	VS41 Single	-	CB03	CA11	CA75	BEB60-8	FB1150-6	HSP4201	MSF54	
CF36	VS42 Double	VR5	CB03	CA11	CA75	BEB60-8	FB1150-6	HSP4201	MSF54	
CF36	VS42 Double	VR5	CB03	CA11	CA75	BEB60-8	FB1150-6	HSP4201	MSF54	
CF36	VS56 Single	-	CB03	CA11	CA75	BEB60-8	FB1150-6	HSP4201	MSF54	
CF36	VS56 Single	-	CB03	CA11	CA75	BEB60-8	FB1150-6	HSP4201	MSF54	
CF36	VS42 Double	VR5	CB03	CA11	CA75	BEB60-8	FB1150-6	HSP4201	MSF54	
CF36	VS42 Double	VR5	CB03	CA11	CA75	BEB60-8	FB1150-6	HSP4201	MSF54	

PART No.	APPLICATION <small>See page 3 for key to Camshaft descriptions</small>	POWER BAND	CAM LIFT INLET/EXHAUST	VALVE LIFT INLET/EXHAUST	DURATION INLET/EXHAUST	TIMING FIGURES	INLET/EXHAUST @ FULL LIFT	V/CLEARANCE INLET/EXHAUST	VALVE LIFT INLET	@ TDC EXHAUST
FORD COSWORTH 16V TURBO Hydraulic Direct acting. Durations quoted at .004" / .10mm checking height										
BD8	GPN SPECIFICATION <small>No piston mods required</small>	1500-6000	.335" 8.50mm	.335" 8.50mm	241°	6/55 50/11	115° 110°	.000" 0.00mm	.009" 0.23mm	.013" 0.33mm
BD10	SPORTS <small>22bhp approx increase</small> <small>Kit Available</small> <small>No Piston Mods Required</small>	1500-6500	.337" 8.56mm	.337" 8.56mm	264°	17/67 62/22	115° 110°	.000" 0.00mm	.026" 0.66mm	.038" 0.96mm
AB07	SPORTS 'R' Baylee Power <small>No piston mods required</small>	1500-6500	.349" 8.85mm	.349" 8.85mm	256°	13/63 58/18	115° 110°	.000" 0.00mm	.009" 0.23mm	.015" 0.38mm
BD14	SPORTS 'R' <small>Piston clearance must be checked</small>	2000-7000	.351" 8.91mm	.351" 8.91mm	261°	16/65 60/21	115° 110°	.000" 0.00mm	.026" 0.66mm	.046" 1.17mm
BD15	COMPETITION	2500-8000	.395" 10.03mm	.395" 10.03mm	258°	24/54 57/21	105° 108°	.000" 0.00mm	.071" 1.80mm	.054" 1.37mm
BD16	RACE	3500-8500	.399" 10.13mm	.399" 10.13mm	265°	28/57 60/25	105° 108°	.000" 0.00mm	.081" 2.05mm	.062" 1.57mm
BD16+	RACE	3500-8500	.413" 10.49mm	.413" 10.49mm	265°	28/57 60/25	105° 108°	.000" 0.00mm	.086" 2.18mm	.062" 1.57mm
FORD COSWORTH 16V TURBO Mechanical Direct acting. Durations quoted at 0.016" / 0.4mm checking height										
CW7	COMPETITION	2500-8000	.400" 10.16mm	.384" 9.75mm	288°	34/74 74/34	110° 110°	.016" 0.41mm	.078" 1.98mm	.068" 1.72mm
CW8	RACE	3500-8500	.423" 10.74mm	.407" 10.34mm	284°	37/67 70/34	105° 105°	.016" 0.41mm	.0117" 2.97mm	.106" 2.69mm
FORD COSWORTH 16V NON-TURBO Hydraulic Direct acting. Durations quoted at .004" / .10mm checking height										
CW22	SPORTS <small>Piston clearances must be checked</small>	2000-7000	.435" 11.04mm	.435" 11.04mm	278°	31/67 67/31	108° 108°	.000" 0.00mm	.080" 2.03mm	.080" 2.03mm
CW23	COMPETITION	2500-7500	.445" 11.30mm	.445" 11.30mm	294°	41/73 73/41	106° 106°	.000" 0.00mm	.124" 3.15mm	.118" 3.00mm
CW24	RACE	3000-8000	.450" 11.43mm	.450" 11.43mm	304°	50/74 74/50	102° 102°	.000" 0.00mm	.166" 4.21mm	.157" 3.99mm
FORD COSWORTH 16V NON-TURBO Mechanical Direct acting. Durations quoted at 0.010" / 0.25mm checking height										
CW12	SPORTS <small>Piston clearances must be checked</small>	2000-7000	.348" 8.83mm	.338" 8.58mm	290°	35/75 75/35	110° 110°	.010" 0.25mm	.077" 1.95mm	.069" 1.75mm
CW13	COMPETITION	2500-8000	.408" 10.36mm	.348" 8.83mm	306° 290°	47/79 75/35	106° 110°	.010" 0.25mm	.130" 3.30mm	.069" 1.75mm
CW14	RACE	3500-8500	.431" 10.94mm	.421" 10.69mm	316°	56/80 80/56	102° 102°	.010" 0.25mm	.168" 4.26mm	.163" 4.14mm
FORD RS2000 DOHC 16V Hydraulic Direct acting. Durations quoted at .004" / .10mm checking height										
RS2001	SPORTS INJECTION <small>Kit Available</small> <small>For use with hydraulic followers 18bhp approx increase</small>	2000-7000	.410" 10.41mm	.397" 10.08mm	260°	20/60 60/20	110° 110°	.000" 0.00mm	.048" 1.22mm	.048" 1.22mm

CAM FOLLOWER	VALVE SPRING	VALVE SPRING RETAINER	CAM BELT	POWER PULLEY	VALVE SPRING KIT	CONROD BOLT	FLYWHEEL BOLT	HEADSTUD KIT	MAINSTUD KIT	OPTIONAL COMPONENTS
CF51	VS34 Double	ST10	CB09	CA28	VSK32P	BEB19-8	FB1150-9	HSCSW53	MSF54	VG05 7mm Bronze Inlet Guide
CF51	VS34 Double	ST10	CB09	CA28	VSK32P	BEB19-8	FB1150-9	HSCSW53	MSF54	VG06 8mm Bronze Exhaust Guide
CF51	VS34 Double	ST10	CB09	CA28	VSK32P	BEB19-8	FB1150-9	HSCSW53	MSF54	S4 Cosworth Conversion Spacers from 4WD to 2WD
CF51	VS34 Double	ST10	CB09	CA28	VSK32P	BEB19-8	FB1150-9	HSCSW53	MSF54	VSK02P Valve Spring Kit with Titanium Retainers and Platforms
CF51	VS34 Double	VRT02	CB09	CA28	VSK02P	BEB19-8	FB1150-9	HSCSW53	MSF54	VSK32P Valve Spring KIT with Steel Retainers and Platforms
CF51	VS34 Double	VRT02	CB09	CA28	VSK02P	BEB19-8	FB1150-9	HSCSW53	MSF54	CF46 Mechanical Follower std. Valve position and std Base Circle, including shim. Follower Stem Length 14.6mm
CF46, CF48 CF47	VS34 Double	VRT02	CB09	CA28	VSK02P	BEB19-8	FB1150-9	HSCSW53	MSF54	CF47 Mechanical Follower std. Valve position and reprofiled cam, including shim. Follower Stem Length 17.2mm
CF46, CF48 CF47	VS34 Double	VRT02	CB09	CA28	VSK02P	BEB19-8	FB1150-9	HSCSW53	MSF54	CF48 Mechanical Follower for use with long valves. Follower Stem Length 4.4mm
CF51	VS34 Double	ST10	CB09	CA28	VSK32P	BEB19-8	FB1150-9	HSCSW53	MSF54	
CF51	VS34 Double	VRT02	CB09	CA28	VSK02P	BEB19-8	FB1150-9	HSCSW53	MSF54	
CF51	VS34 Double	VRT02	CB09	CA28	VSK02P	BEB19-8	FB1150-9	HSCSW53	MSF54	
CF46, CF48 CF47	VS34 Double	ST10	CB09	CA28	VSK32P	BEB19-8	FB1150-9	HSCSW53	MSF54	
CF46, CF48 CF47	VS34 Double	VRT02	CB09	CA28	VSK02P	BEB19-8	FB1150-9	HSCSW53	MSF54	
CF46, CF48 CF47	VS34 Double	VRT02	CB09	CA28	VSK02P	BEB19-8	FB1150-9	HSCSW53	MSF54	
CF69	-	-	-	S65	-	-	-	-	-	

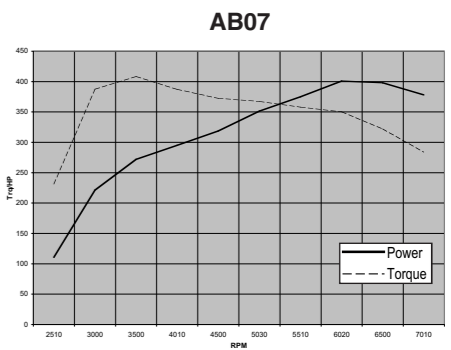

PART No.	APPLICATION See page 3 for key to Camshaft descriptions	POWER BAND	CAM LIFT INLET/EXHAUST	VALVE LIFT INLET/EXHAUST	DURATION INLET/EXHAUST	TIMING FIGURES	INLET/EXHAUST @ FULL LIFT	V/CLEARANCE INLET/EXHAUST	VALVE LIFT INLET	@ TDC EXHAUST
----------	--	------------	---------------------------	-----------------------------	---------------------------	-------------------	------------------------------	------------------------------	---------------------	------------------

FORD I4 16V DURATEC 2.0 Direct acting. Durations quoted at .010" / .25mm checking height

D-TEC10	SPORTS 'R' Throttle bodies 4 into 1 manifold	2500-7500	.412" 10.46mm	.402" 10.21mm	260°	20/60 55/25	110° 105°	.010" 0.25mm	.040" 1.01mm	.056" 1.42mm
D-TEC20	COMPETITION Piston modifications Throttle bodies 4 into 1 manifold	2500-7500	.444" 11.27mm	.434" 11.02mm	268°	24/64 59/29	110° 105°	.010" 0.25mm	.050" 1.27mm	.073" 1.85mm
D-TEC35	COMPETITION <i>Autograss</i> Piston modifications Throttle bodies 4 into 1 exhaust	3500-8000	.445" 11.30mm	.435" 11.05mm	280°	32/68 66/34	108° 106°	.010" 0.25mm	.125" 3.17mm	.128" 3.25mm
D-TEC45	COMPETITION <i>Autograss</i> Piston modifications Throttle bodies 4 into 1 exhaust	3750-8250	.457 .431" 11.60mm 10.94mm	.447 .421" 11.35mm 10.69mm	294° 284°	39/75 70/34	108° 108°	.010" 0.25mm	.120" 3.05mm	.094" 2.38mm
D-TEC50	COMPETITION <i>Rallycross</i> Piston modifications Throttle bodies 4 into 1 exhaust	4000-8500	.457" 11.60mm	.447" 11.35mm	296°	40/76 74/42	108° 106°	.010" 0.25mm	.120" 3.05mm	.120" 3.05mm
D-TEC65	COMPETITION <i>Rallycross</i> Piston modifications Throttle bodies 4 into 1 exhaust	4250-8750	.460 .444" 11.68mm 11.27mm	.450 .434" 11.43mm 11.02mm	300° 294°	42/78 73/41	108° 106°	.010" 0.25mm	.128" 3.25mm	.125" 3.17mm
D-TEC70	HOT ROD	4000-8000	.486 .486" 12.35mm 12.35mm	.476 .476" 12.10mm 12.10mm	296° 296°	42/74 68/48	106° 100°	.010" 0.25mm	.135" 3.45mm	.161" 4.1mm
D-TEC80	RACE Piston modifications Throttle bodies 4 into 1 exhaust	4500-9000	.472" .444" 11.98mm 11.27mm	.462" .434" 11.73mm 11.02mm	310° 294°	49/81 73/41	106° 106°	.010" 0.25mm	.141" 3.58mm	.125" 3.17mm

FORD I4 16V DURATEC 2.3 L Direct acting. Durations quoted at .010" / .25mm checking height

D-TEC2330	SPORTS 'R' Piston modification Throttle bodies 4:1 exhaust manifold	2500-7500	.417" .417" 10.60mm 10.60mm	.407" .407" 10.35mm 10.35mm	268° 268°	24/64 59/29	105° 110°	.010" 0.25mm	.101" 2.56mm	.062" 1.57mm
D-TEC2350	COMPETITION Piston modification Throttle bodies 4:1 exhaust manifold	3000-7500	.456" .456" 11.58mm 11.58mm	.446" .446" 11.33mm 11.33mm	280° 280°	34/66 68/32	106° 108°	.010" 0.25mm	.140" 3.55mm	.125" 3.17mm
D-TEC2370	COMPETITION Piston modification Throttle bodies 4:1 exhaust manifold	3500-7750	.500" .500" 12.70mm 12.70mm	.490" .490" 12.45mm 12.45mm	284° 284°	36/68 70/34	106° 108°	.010" 0.25mm	.144" 3.65mm	.136" 3.45mm

CAM FOLLOWER	VALVE SPRING	VALVE SPRING RETAINER	VALVE SPRING KIT	POWER PULLEY	CONROD BOLT	HEAD STUD KIT	MAIN STUD KIT	OPTIONAL COMPONENTS
--------------	--------------	-----------------------	------------------	--------------	-------------	---------------	---------------	---------------------

-	VS60 Single	-	-	S77	BEB46-8	HSFD04	MSFD03	DURATEC I4 PRODUCTS AND INFORMATION FBFD02 ARP Flywheel Bolts S77 Slotted cam gears to run with OE chain and Kent Bespoke Camshafts. These are included when cams are purchased. CBFD01 ARP Crank Bolt. VS60 Conical valve springs are designed to suit the OE retainer and stem seal. VSK26P Valve spring kit containing steel spring retainers and platforms to suit the OE stem seal. VSK24P Valve spring kit containing titanium spring retainers and platforms to suit the OE stem seal. Kent Cams bespoke camshafts are supplied with adjustable timing wheels as used on WRC engines. Duratec cams are also available for use with OE gears.
-	VS60 Single	-	-	S77	BEB46-8	HSFD04	MSFD03	
-	VS60 Single	-	-	S77	BEB46-8	HSFD04	MSFD03	
-	VS60 Single	-	-	S77	BEB46-8	HSFD04	MSFD03	
-	VS59 Double	ST26	VSK26P	S77	BEB46-8	HSFD04	MSFD03	
-	VS59 Double	ST26	VSK26P	S77	BEB46-8	HSFD04	MSFD03	
-	VS59 Double	ST26	VSK26P	S77	BEB46-8	HSFD04	MSFD03	
-	VS59 Double	VRT26	VSK24P	S77	BEB46-8	HSFD04	MSFD03	
-	VS60 Single	-	-	S77	BEB46-8	HSFD04	MSFD03	
-	VS60 Single	-	-	S77	BEB46-8	HSFD04	MSFD03	

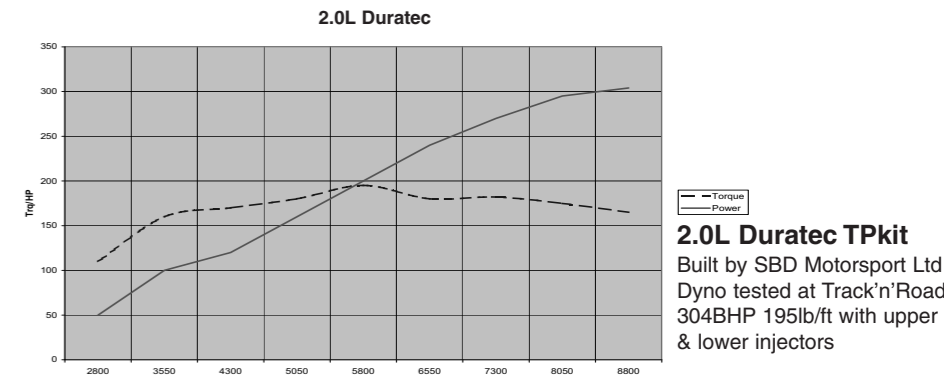
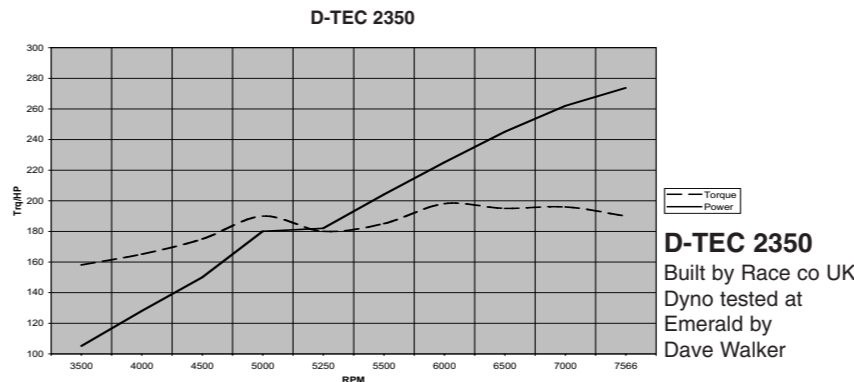
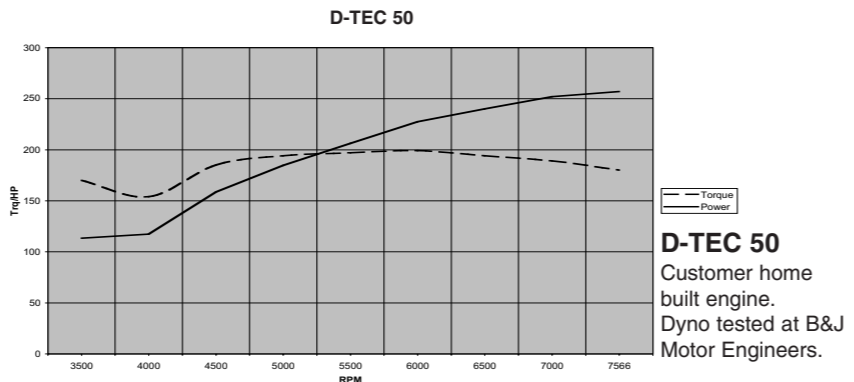
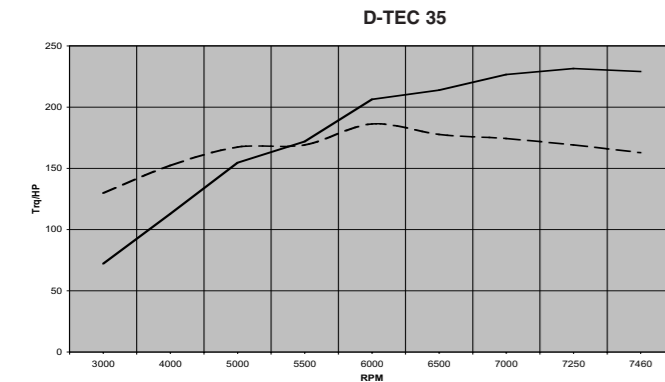

PART No.	APPLICATION See page 3 for key to Camshaft descriptions	POWER BAND	CAM LIFT INLET/EXHAUST	VALVE LIFT INLET/EXHAUST	DURATION INLET/EXHAUST	TIMING FIGURES	INLET/EXHAUST @ FULL LIFT	V/CLEARANCE INLET/EXHAUST	VALVE LIFT INLET	@ TDC EXHAUST
----------	--	------------	---------------------------	-----------------------------	---------------------------	-------------------	------------------------------	------------------------------	---------------------	------------------

FORD ZETEC 16V 1.6/1.8/2.0 ESCORT - FIESTA - MONDEO Pre 1998 Silver Top Engine

Direct acting. Durations quoted at .004" / .10mm checking height

FZ1601 Kit Available	SPORTS <i>12bhp approx increase</i> Suitable for 1.6. For use with hydraulic followers	1500-6500	.368" .341" 9.34mm 8.66mm	.368" .341" 9.34mm 8.66mm	262°	21/61 61/21	110° 110°	.000" 0.00mm	.037" 0.94mm	.031" 0.79mm
FZ1801 Kit Available	SPORTS <i>20bhp approx increase</i> Suitable for 1.8. For use with hydraulic followers	1500-6500	.397" .368" 10.08mm 9.34mm	.397" .368" 10.08mm 9.34mm	262°	21/61 61/21	110° 110°	.000" 0.00mm	.048" 1.22mm	.036" 0.91mm
FZ1802 Kit Available	SPORTS 'R' <i>14bhp approx increase</i> Suitable for 1.8 (130BHP). For use with hydraulic followers	1500-6500	.410" .375" 10.41mm 9.52mm	.410" .375" 10.41mm 9.52mm	262°	21/61 61/21	110° 110°	.000" 0.00mm	.048" 1.22mm	.022" 0.56mm
FZ2001 Kit Available	SPORTS <i>12bhp approx increase</i> Suitable for 2.0. For use with hydraulic followers	1500-6500	.410" .375" 10.41mm 9.52mm	.410" .375" 10.41mm 9.52mm	262°	21/61 61/21	110° 110°	.000" 0.00mm	.048" 1.22mm	.022" 0.56mm
FZ2002	COMPETITION For use with hydraulic followers	2500-7000	.435" 11.04mm	.435" 11.04mm	278°	31/67 67/31	108° 106°	.000" 0.00mm	.080" 2.03mm	.089" 2.26mm
FZ2025	COMPETITION For use with standard size solid followers	3000-7500	.441" .441" 11.2mm 11.2mm	.431" .431" 10.95mm 10.95mm	298°	41/77 75/43	108° 106°	.010" 0.25mm	.110" 2.8mm	.118" 3.0mm
FZ2003	COMPETITION For use with oversize solid followers	3750-8000	.438" 11.12mm	.428" 10.87mm	304°	46/78 78/46	106° 106°	.010" 0.25mm	.141" 3.58mm	.125" 3.17mm
FZ2004	RACE For use with oversize solid followers	4000-8500	.450" 11.43mm	.440" 11.17mm	317°	52/85 85/52	106° 106°	.010" 0.25mm	.162" 4.11mm	.155" 3.94mm

FORD FOCUS ZETEC 16V 1.8 Post 1998 Black Top Engine

FOCUS18	SPORTS	2000-6000	.356" .338" 9.05mm 8.60mm	.346" .328" 8.80mm 8.35mm	278° 270°	29/69 65/25	110° 110°	.010" 0.25mm	.020" 0.52mm	.015" 0.37mm
---------	---------------	-----------	------------------------------	------------------------------	-----------	-------------	-----------	-----------------	-----------------	-----------------

FORD FOCUS ZETEC 16V 2.0 Post 1998 Black Top Engine

Direct acting. Durations quoted at .010" / .25mm checking height

FOCUS1	SPORTS	2000-6000	.392" .364" 9.95mm 9.25mm	.382" .354" 9.70mm 9.00mm	292° 278°	36/76 69/29	110° 110°	.010" 0.25mm	.053" 1.34mm	.027" 0.68mm
FOCUS12	SPORTS 'R' Modified Injection	2000-6500	.406" .392" 10.30mm 9.95mm	.396" .382" 10.05mm 9.70mm	292°	36/76 76/36	110° 110°	.010" 0.25mm	.084" 2.13mm	.043" 1.09mm
FOCUS2	COMPETITION Modified Injection	3000-7500	.444" .431" 11.27mm 10.94mm	.434" .421" 11.02mm 10.69mm	297° 284°	42/75 68/36	106° 106°	.010" 0.25mm	.126" 3.20mm	.102" 2.59mm
FOCUS3	COMPETITION Modified Injection	3000-7500	.444" .444" 11.27mm 11.27mm	.434" .434" 11.02mm 11.02mm	297°	42/75 75/42	106° 106°	.010" 0.25mm	.126" 3.20mm	.122" 3.10mm

FORD FOCUS RS 16V 2.0L 2002 - 2003

Direct acting. Durations quoted at .016" / .40mm checking height

FOCUSRS1	SPORTS 'R'	2000-6000	.393" .366" 10.00mm 9.30mm	.383" .356" 9.75mm 9.05mm	268° 252°	22/66 58/14	112° 112°	.010" 0.25mm	.046" 1.18mm	.022" 0.57mm
----------	-------------------	-----------	-------------------------------	------------------------------	-----------	-------------	-----------	-----------------	-----------------	-----------------

CAM FOLLOWER	VALVE SPRING	VALVE SPRING RETAINER	VALVE SPRING KIT	POWER PULLEY	CONROD BOLT	HEAD STUD KIT	MAIN STUD KIT
--------------	--------------	-----------------------	------------------	--------------	-------------	---------------	---------------

CF52	VS46 Single	VR19 VR14	-	CA59	BEB17-8	HSFX02	MSFZ04	FORD ZETEC 16V 1.8/2.0:- VR19 Alloy Retainers for VS46. Triple Groove Valve VR14 Alloy Retainers for VS46. Single Groove Valve CB10 Cambelt FBFZ01 ARP Flywheel Bolts
CF52	VS46 Single	VR19 VR14	-	CA59	BEB17-8	HSFX02	MSFZ04	
CF52	VS46 Single	VR19 VR14	-	CA59	BEB17-8	HSFX02	MSFZ04	
CF52	VS46 Single	VR19 VR14	-	CA59	BEB17-8	HSFX02	MSFZ04	
CF52	VS46 Single	VR19 VR14	-	CA59	BEB17-8	HSFX02	MSFZ04	CF56 Oversize lightweight followers (Diameter 32mm) **VRT11 Titanium Retainers for VS34. (Single Groove Valve) **VRT18 Titanium Retainers for VS34. (Triple Groove Valve) VSK18P Valve Spring Kit. (Triple Groove Valve) VSK11P Valve Spring Kit. (Single Groove Valve) **VG16 Bronze Guide Including Seal. For use with Valve Spring Kit BEB17-8 Conrod Bolts may require the cap to be reamed 8mm for fitment
CF57	VS51 Single	VR19 VR14	-	CA59	BEB17-8	HSFX02	MSFZ04	
CF56**	VS34** Double	VRT11 VRT18**	VSK11**P VSK18**P	CA59	BEB17-8	HSFX02	MSFZ04	
CF56**	VS34** Double	VRT11 VRT18**	VSK11**P VSK18**P	CA59	BEB17-8	HSFX02	MSFZ04	
-	-	-	-	CA59	BEB36-8	HSFX02	MSF5405	
-	-	-	-	CA59	BEB36-8	HSFX02	MSF5404	
CF66	-	-	-	CA59	BEB36-8	HSFX02	MSF5404	
CF66	VS60 Single	-	-	CA59	BEB36-8	HSFX02	MSF5404	
CF66	VS60 Single	-	-	CA59	BEB36-8	HSFX02	MSF5404	
-	-	-	-	CA59	BEB36-8	HSFX02	MSF5405	

CF66 are lightweight Followers with shim underneath and just require the shim machining to size. Once set there are no little adjusters to come loose and cause any unnecessary damage. This is the same principle as the famous Ford BDA.

CB28 Cambelt
VS60 To fit OE Valve Spring Retainer

PART No.	APPLICATION See page 3 for key to Camshaft descriptions	POWER BAND	CAM LIFT INLET/EXHAUST	VALVE LIFT INLET/EXHAUST	DURATION INLET/EXHAUST	TIMING FIGURES	INLET TIMING @ FULL LIFT	V/CLEARANCE INLET/EXHAUST	VALVE LIFT INLET	@ TDC EXHAUST
----------	--	------------	---------------------------	-----------------------------	---------------------------	-------------------	-----------------------------	------------------------------	---------------------	------------------

FORD FIESTA VCTi 1.6 16V

FZVCT02	COMPETITION NEW	3000-8000	.440" 11.20mm	.430" 10.95mm	295°	VCT	OE Timing Slots	.010" 0.25mm	N/A	N/A
---------	---	-----------	-------------------------	-------------------------	------	-----	-----------------	------------------------	-----	-----

FORD ZETEC 'S' 1.25/1.4/1.6 16V 'Sigma'

Direct acting. Durations quoted at .010" / .25mm checking height

FZ1411	SPORTS 'R' Suitable 1.25/1.4 version	1500-6000	.275" .275" 7.25mm 7.25mm	.265" .265" 7.00mm 7.00mm	264° 264°	22/62 60/24	110° 108°	.010" 0.25mm	.015" 0.39mm	.010" 0.25mm
FZ1611	SPORTS 'R' Suitable 1.6 version	1500-6000	.313" .291" 7.95mm 7.39mm	.303" .281" 7.70mm 7.14mm	264° 262°	22/62 56/26	110° 105°	.010" 0.25mm	.015" 0.38mm	.023" 0.58mm
FZ1613	COMPETITION Carburettor - Throttle Bodies	3000-7500	.408" .380" 11.36mm 9.65mm	.398" .370" 10.10mm 9.40mm	306° 295°	47/79 73/42	106° 105°	.010" 0.25mm	.130" 3.30mm	.105" 2.66mm

FORD PUMA 1.7 DOHC 16V VVT

Direct acting. Durations quoted at .010" / .25mm checking height

PUMA1	SPORTS 'R'	2000-6800	.352" .313" 8.95mm 7.95mm	.342" .303" 8.75mm 7.75mm	284° 264°	-	ORIGINAL	.010" 0.25mm	N/A	N/A
-------	------------	-----------	--	--	-----------	---	----------	------------------------	-----	-----

FORD KA 1.3 OHV

Valve Lifts are quoted using a theoretical Rocker Ratio of 1.52:1 Durations quoted at .016"/.40mm checking height

KA11 Kit Available	SPORTS <i>6bhp approx increase</i>	1500-5500	.220" .220" 5.58mm 5.58mm	.324" .322" 8.22mm 8.18mm	216° 220°	6/30 36/4	102°	.010" .012" 0.25mm 0.30mm	.023" 0.58mm	N/A
KA12	COMPETITION Modified ECU and Exhaust system	2500-6500	.228" .228" 5.79mm 5.79mm	.336" .334" 8.53mm 8.48mm	248°	24/44 44/24	100°	.010" .012" 0.25mm 0.30mm	.084" 2.13mm	N/A

FORD V6 2.3 2.8 TAUNUS Please state year when ordering as bearing size changed September 1982. Pre 82 No1 Bearing Journal Diameter: 1.652"/41.90mm Post 82 No 1 Bearing Journal Diameter: 1.730"/43.90mm

V6T1 Kit Available	MILD ROAD <i>14bhp approx increase</i>	1000-5500	.288" .293" 7.31mm 7.43mm	.409" .414" 10.39mm 10.51mm	270° 280°	32/58 73/27	103°	.014" .016" 0.36mm 0.41mm	.093" 2.36mm	N/A
V6T2 Kit Available	SPORTS <i>16bhp approx increase</i>	1500-6500	.293" 7.43mm	.416" .414" 10.56mm 10.51mm	280°	37/63 73/27	103°	.014" .016" 0.36mm 0.41mm	.122" 3.09mm	N/A
V6T3 Kit Available	SPORTS 'R' <i>20bhp approx increase</i>	2000-6500	.309" 7.84mm	.440" .438" 11.17mm 11.12mm	290°	42/68 78/32	103°	.014" .016" 0.36mm 0.41mm	.137" 3.48mm	N/A
V6T4	RACE	3000-7500	.324" 8.24mm	.462" .460" 11.73mm 11.68mm	300°	47/73 83/37	103°	.014" .016" 0.36mm 0.41mm	.164" 4.16mm	N/A

FORD V6 2.8 TAUNUS INJECTION Please state year when ordering as bearing size changed September 1982. Pre 82 No1 Bearing Journal Diameter: 1.652"/41.90mm Post 82 No 1 Bearing Journal Diameter: 1.730"/43.90mm

V6T21 Kit Available	SPORTS INJECTION <i>22bhp approx increase</i> Also suitable for Turbo applications	2000-6000	.280" 7.11mm	.397" .395" 10.08mm 10.03mm	276°	24/72 72/24	114°	.014" .016" 0.36mm 0.41mm	.053" 1.34mm	N/A
V6T31 Kit Available	SPORTS 'R' <i>30bhp approx increase</i> For modified injection systems	2500-6500	.310" 7.87mm	.441" .439" 11.20mm 11.15mm	284°	32/72 72/32	110°	.014" .016" 0.36mm 0.41mm	.103" 2.61mm	N/A

FORD V6 2.9 INJECTION Mechanical Followers only

Valve Lifts are quoted using a theoretical Rocker Ratio of 1.47:1 Durations quoted at .016" / .40mm checking height

V6T45 Kit Available	SPORTS INJECTION <i>22bhp approx increase</i>	2000-6000	.280" 7.11mm	.397" .395" 10.08mm 10.03mm	276°	24/72 72/24	114°	.014" .016" 0.36mm 0.41mm	.053" 1.34mm	N/A
V6T46	SPORTS 'R' For modified injection systems	2500-6000	.310" 7.87mm	.441" .439" 11.20mm 11.15mm	284°	32/72 72/32	110°	.014" .016" 0.36mm 0.41mm	.103" 2.61mm	N/A

CAM FOLLOWER	VALVE SPRING	CONROD BOLT	MAIN STUD KIT	HEAD STUD KIT	CAMBELT	POWER PULLEY	FLYWHEEL BOLTS
--------------	--------------	-------------	---------------	---------------	---------	--------------	----------------

-	-	-	MSFSV45	HSFSV65	-	-	-
---	---	---	---------	---------	---	---	---

-	-	-	-	-	-	CA96	-
---	---	---	---	---	---	------	---

-	-	-	-	-	-	CA96	-
---	---	---	---	---	---	------	---

-	-	-	-	-	-	CA96	-
---	---	---	---	---	---	------	---

-	-	-	-	-	CB32	-	-
---	---	---	---	---	------	---	---

CF49	VS5 Single	-	-	-	-	-	-	KA12 is to be used in conjunction with exhaust system and modified ECU. Ford can supply, Part No.	9097104 - Manifold 9097140 - System to suit above 9097106 - ECU
------	---------------	---	---	---	---	---	---	---	---

CF49	VS5 Single	-	-	-	-	-	-		
------	---------------	---	---	---	---	---	---	--	--

Valve Lifts are quoted using a theoretical Rocker Ratio of 1.47:1 Durations quoted at .016" / .40mm checking height

CF10	VS25 Single	BEB16-12	MSF64	-	-	-	-	
CF10	VS25 Single	BEB16-12	MSF64	-	-	-	-	
CF10	VS25 Single	BEB16-12	MSF64	-	-	-	-	
CF10	VS42x1.5 Double	BEB16-12	MSF64	-	-	-	-	

Valve Lifts are quoted using a theoretical Rocker Ratio of 1.47:1 Durations quoted at .016" / .40mm checking height

CF10	VS25 Single	BEB16-12	MSF64	-	-	-	-	V6T21 KIT will improve your 2.8 Injection performance by approximately 22bhp. The Cam Kit contains Camshaft, Valve Springs, and Cam Followers.
CF10	VS25 Single	BEB16-12	MSF64	-	-	-	-	

CF10	VS25 Single	BEB16-12	MSF64	-	-	-	-
CF10	VS25 Single	BEB16-12	MSF64	-	-	-	-

PART No.	APPLICATION <small>See page 3 for key to Camshaft descriptions</small>	POWER BAND	CAM LIFT INLET/EXHAUST	VALVE LIFT INLET/EXHAUST	DURATION INLET/EXHAUST	TIMING FIGURES	INLET/ EXHAUST @ FULL LIFT	V/CLEARANCE INLET/EXHAUST	VALVE LIFT INLET	@ TDC EXHAUST
----------	---	------------	---------------------------	-----------------------------	---------------------------	-------------------	-------------------------------	------------------------------	---------------------	------------------

FORD V6 3.0 ESSEX ENGINE All Cams in this range will fit with no additional machining required but must be checked. Valve Lifts are quoted using a theoretical Rocker Ratio of 1.47:1 Durations quoted at .016" / .40mm checking height

V61 <small>Kit Available</small>	MILD ROAD <i>14bhp approx increase</i>	1000-5500	.273" 6.93mm	.387" 9.82mm	270°	26/64 64/26	109°	.014" 0.36mm	.062" 1.57mm	N/A -
V63 <small>Kit Available</small>	FAST ROAD <i>18bhp approx increase</i>	1500-6000	.315" 7.99mm	.447" 11.35mm	276°	30/66 66/30	110°	.016" 0.41mm	.087" 2.21mm	N/A -
V62 <small>Kit Available</small>	FAST ROAD/RALLY <i>24bhp approx increase</i>	2000-6500	.264" 6.70mm	.376" 9.55mm	.374" 9.49mm	290°	37/73 73/37	.108" 2.70mm	.082" 2.08mm	N/A -

There is no substitute for this next range of cams. They are all high lift/ high torque cams with phenomenal mid-range and top end power. All cams need Kent Special Valve Springs and additional machining may be required.

V65	FAST ROAD/RALLY	1500-6000	.309" 7.84mm	.440" 11.17mm	.438" 11.12mm	290°	42/68 78/32	.103" 2.62mm	.137" 3.48mm	N/A -
V66	RALLY	2500-6500	.324" 8.22mm	.462" 11.73mm	.460" 11.68mm	300°	47/73 83/37	.103" 2.62mm	.164" 4.16mm	N/A -
V67	RACE	3500-7500	.339" 8.60mm	.484" 12.29mm	.482" 12.24mm	310°	52/78 88/42	.103" 2.62mm	.187" 4.75mm	N/A -
V68	GP1 SPECIFICATION	4000-8000	.350" 8.89mm	.498" 12.65mm		320°	56/84 84/56	.104" 2.64mm	.170" 4.32mm	N/A -

HONDA K20A Valve Lifts are quoted using a theoretical Rocker Ratio of 1.7:1. Duration quoted at .010" / .25mm checking height

K20-2A	COMPETITION	2000-8000	.295" 7.5mm	.274" 6.95mm	.492" 12.5mm	.455" 11.56mm	297° 292°	VVT	Manufacturer's Timing Marks	.010" 0.25mm	.010" 0.25mm	N/A -	N/A -
K20-3A	COMPETITION	2500-8000	.303" 7.7mm	.287" 7.3mm	.505" 12.84mm	.479" 12.16mm	295° 290°	VVT	Manufacturer's Timing Marks	.010" 0.25mm	.010" 0.25mm	N/A -	N/A -

JAGUAR 6 Cylinder Direct Acting. Durations quoted at .010" / .25mm checking height

JAG2	FAST ROAD	2000-6500	.415" 10.54mm	.409" 10.38mm	.407" 10.44553mm	282°	35/67 67/35	106° 106°	.008" 0.20mm	.010" 0.25mm	.110" 2.79mm	.095" 2.41mm
JAG3	RALLY	2500-7000	.426" 10.82mm	.420" 10.66mm	.418" 10.61mm	308°	49/79 79/49	105° 105°	.008" 0.20mm	.010" 0.25mm	.152" 3.86mm	.143" 3.63mm
JAG4	RACE	3000-7500	.445" 11.30mm	.439" 11.15mm	.437" 11.10mm	310°	45/85 85/45	110° 110°	.008" 0.20mm	.010" 0.25mm	.117" 2.97mm	.108" 2.74mm

JAGUAR V12 Direct Acting. Durations quoted at .010" / .25mm checking height

JAG6	FAST ROAD	2000-6500	.415" 10.54mm	.409" 10.38mm	.407" 10.43mm	282°	35/67 67/35	106°	.008" 0.20mm	.010" 0.25mm	.110" 2.79mm	N/A -
JAG7	RALLY	2500-7000	.426" 10.82mm	.420" 10.66mm	.408" 10.61mm	308°	49/79 79/49	105°	.008" 0.20mm	.010" 0.25mm	.152" 3.86mm	N/A -
JAG8	RACE	3000-7500	.441" 11.20mm	.435" 11.04mm	.433" 10.99mm	310°	45/85 85/45	110°	.008" 0.20mm	.010" 0.25mm	.117" 2.97mm	N/A -

CAM FOLLOWER	VALVE SPRING	VALVE SPRING RETAINER	MAIN STUD KIT	HEAD STUD KIT	CONROD BOLTS	OPTIONAL COMPONENTS
--------------	--------------	-----------------------	---------------	---------------	--------------	---------------------

CF9	VS12 Single	-	MSF40	HSF38	BEB51-12	
CF9	VS12 Single	-	MSF40	HSF38	BEB51-12	
CF9	VS12 Single	-	MSF40	HSF38	BEB51-12	
CF9	VS12 Single	-	MSF40	HSF38	BEB51-12	
CF9	VS12 Single	-	MSF40	HSF38	BEB51-12	
CF9	VS12 Single	-	MSF40	HSF38	BEB51-12	
CF9	VS12 Single	-	MSF40	HSF38	BEB51-12	
CF9	VS12 Single	-	MSF40	HSF38	BEB51-12	
CF9	VS12 Single	-	MSF40	HSF38	BEB51-12	
CF58	VS42x1.5 Double	-	MSF40	HSF38	BEB51-12	

-	20411.216	-	-	HSHON4701	BEB55-8	S85 K20A exhaust adjustable cam gear
-	20411.216	-	-	HSHON4701	BEB55-8	

-	-	-	-	-	-	Jaguar Race Camshafts can be manufactured from Steel Billet or Chillcast castings, so more aggressive profiles can be used. For example the profile D598 is a popular cam from our direct acting files and has .501" lift and could not be reprofiled on to an original cam. Cam Followers are custom made as customers have follower bores machined oversize. Most common is the 1.400" O.D. which does not require tappet guides to be replaced.
-	-	-	-	-	-	
-	-	-	-	-	-	
-	-	-	-	-	-	
-	-	-	-	-	-	
-	-	-	-	-	-	

PART No.	APPLICATION <small>See page 3 for key to Camshaft descriptions</small>	POWER BAND	CAM LIFT INLET/EXHAUST	VALVE LIFT INLET/EXHAUST	DURATION INLET/EXHAUST	TIMING FIGURES	INLET/EXHAUST @ FULL LIFT	V/CLEARANCE INLET/EXHAUST	VALVE LIFT INLET	@ TDC EXHAUST
----------	---	------------	---------------------------	-----------------------------	---------------------------	-------------------	------------------------------	------------------------------	---------------------	------------------

LOTUS ELISE - EXIGE 1.8 2ZZ-GE VVTL-i Valve lifts are quoted using a theoretical Rocker Ratio of 1.7:1 and duration quoted as Vtec valve period

LEVVT01	SPORT <i>OE Replacement</i>	2000-8500	6.7mm 6.0mm	11.2mm 10.0mm	292° 276°	VVT	Manufacturer's Timing Marks	0.15mm 0.25mm	N/A	N/A
LEVVT02	SPORTS R	2000-8500	7.0mm 6.35mm	11.75mm 10.55mm	300° 285°	VVT	Manufacturer's Timing Marks	0.15mm 0.25mm	N/A	N/A

LOTUS ELISE 1.8 'K' Series Direct Acting. Duration of hydraulic profiles quoted at .004" / .10mm. Mechanical profiles checked at .010" / .25mm checking height

LE1811 <small>Kit Available</small>	SPORTS INJECTION <i>22bhp approx increase</i>	2000-6000	.425" 10.79mm	.425" 10.79mm	258°	19/59 59/19	110° 110°	.000" 0.00mm	.057" 1.45mm	.051" 1.30mm
LE1812	SPORTS 'R'	2000-6000	.431" 10.94mm	.431" 10.94mm	266°	23/63 63/23	110° 110°	.000" 0.00mm	.065" 1.65mm	.055" 1.40mm
LE1813	COMPETITION <i>Modified injection</i>	3000-7500	.435" 11.05mm	.435" 11.05mm	276°	30/66 66/30	108° 108°	.000" 0.00mm	.090" 2.28mm	.090" 2.28mm

LOTUS TWIN-CAM - BDA-BDG COSWORTH YB Direct Acting. Durations quoted at .010" / .25mm checking height

CPL2	<small>It is impossible to state applications and power bands due to the wide combinations of inlet and exhaust profiles.</small>		.360" 9.14mm	.350" 8.89mm	270°	25/65 65/25	110°	.010" 0.25mm	.071" 1.80mm	.068" 1.72mm
BD3			.348" 8.83mm	.338" 8.58mm	290°	35/75 75/35	110°	.010" 0.25mm	.077" 1.95mm	.069" 1.75mm
L2			.354" 8.99mm	.344" 8.73mm	302°	49/73 73/49	102°	.010" 0.25mm	.122" 3.10mm	.127" 3.22mm
L14			.415" 10.54mm	.407" 10.33mm	282°	35/67 67/35	106°	.008" 0.20mm	.110" 2.79mm	.095" 2.41mm
L1			.408" 10.36mm	.398" 10.10mm	306°	47/79 71/55	106°	.010" 0.25mm	.130" 3.30mm	.127" 3.22mm
BD4			.431" 10.94mm	.421" 10.69mm	316°	56/80 80/56	102°	.010" 0.25mm	.168" 4.26mm	.163" 4.14mm
F1			.412" 10.46mm	.402" 10.21mm	324°	60/84 84/60	102°	.010" 0.25mm	.187" 4.75mm	.172" 4.37mm
PH4			.441" 11.20mm	.436" 11.07mm	314°	52/82 82/52	105°	.005" 0.13mm	.172" 4.37mm	.167" 4.24mm
PH5			.438" 11.12mm	.428" 10.87mm	324°	60/84 84/60	102°	.010" 0.25mm	.195" 4.95mm	.190" 4.82mm
DA2			.380" 9.65mm	.370" 9.40mm	295°	42/73 73/42	105°	.010" 0.25mm	.113" 2.87mm	.105" 2.66mm
DA10			.410" 10.41mm	.400" 10.16mm	312°	54/78 78/54	102°	.010" 0.25mm	.159" 4.03mm	.149" 3.78mm
DA12			.460" 11.68mm	.450" 11.43mm	322°	61/81 81/61	100°	.010" 0.25mm	.210" 5.33mm	.202" 5.13mm
DA19			.454" 11.54mm	.444" 11.29mm	308°	48/80 80/48	106°	.010" 0.25mm	.139" 3.54mm	.139" 3.54mm
EA1			.460" 11.68mm	.450" 11.43mm	324°	60/84 84/60	102°	.010" 0.25mm	.190" 4.82mm	.185" 4.70mm

CAM FOLLOWER	VALVE SPRING	VALVE SPRING RETAINER	VALVE SPRING KITS	POWER PULLEY	CAM BELT	CONROD BOLT	FLYWHEEL BOLT	HEADSTUD KIT	MAINSTUD KIT	OPTIONAL COMPONENTS
--------------	--------------	-----------------------	-------------------	--------------	----------	-------------	---------------	--------------	--------------	---------------------

-	-	-	-	-	-	-	-	-	-	
-	-	-	-	-	-	-	-	-	-	

CF63	VS51 Single	ST69	VSK29	CA67	CB27	BEB37-8	FBKS03	HSRK4209	-	
CF63	VS51 Single	ST69	VSK29	CA67	CB27	BEB37-8	FBKS03	HSRK4209	-	
CF63	VS51 Single	ST69	VSK29	CA67	CB27	BEB37-8	FBKS03	HSRK4209	-	



CF40	-	-	-	S45	-	BEB09-8	FB900-6	HSL68 HSC48	MSF375	
CF40	-	-	-	S45	-	BEB09-8	FB900-6	HSL68 HSC48	MSF375	CF40 are for Lotus T/C only.
CF40	-	-	-	S45	-	BEB09-8	FB900-6	HSL68 HSC48	MSF375	CA84 BDA-BDG Power Pulleys
CF40	-	-	-	S45	-	BEB09-8	FB900-6	HSL68 HSC48	MSF375	S45 are for Lotus T/C only.
CF40	-	-	-	S45	-	BEB09-8	FB900-6	HSL68 HSC48	MSF375	BEB09-8 are for Lotus T/C only.
CF40	-	-	-	S45	-	BEB09-8	FB900-6	HSL68 HSC48	MSF375	HSL68 are for Lotus T/C only.
CF40	-	-	-	S45	-	BEB09-8	FB900-6	HSL68 HSC48	MSF375	HSC48 are for Ford BDA (4.65" oal).
CF40	-	-	-	S45	-	BEB09-8	FB900-6	HSL68 HSC48	MSF375	FB900-6 are for Lotus T/C only.
CF40	-	-	-	S45	-	BEB09-8	FB900-6	HSL68 HSC48	MSF375	Lotus Twin Cam, BDG and BDA cams can all be produced from chillcast or steel billet.
CF40	-	-	-	S45	-	BEB09-8	FB900-6	HSL68 HSC48	MSF375	
CF40	-	-	-	S45	-	BEB09-8	FB900-6	HSL68 HSC48	MSF375	

PART No.	APPLICATION <small>See page 3 for key to Camshaft descriptions</small>	POWER BAND	CAM LIFT INLET/EXHAUST	VALVE LIFT INLET/EXHAUST	DURATION INLET/EXHAUST	TIMING FIGURES	INLET/EXHAUST @ FULL LIFT	V/CLEARANCE INLET/EXHAUST	VALVE LIFT INLET	@ TDC EXHAUST
LOTUS 907 16V 2.2 Direct Acting. Durations quoted at .010" / .25mm checking height										
907-L14	SPORTS	2500-6500	.415" 10.54mm	.407" 10.33mm	282°	35/67 67/35	106° 106°	.008" 0.20mm	.110" 2.79mm	.095" 2.41mm
907-L1	COMPETITION	2500-7000	.408" 10.36mm	.398" 10.10mm	306°	47/79 79/47	106° 106°	.010" 0.25mm	.130" 3.30mm	.127" 3.22mm
907BD4	RACE	3000-7500	.431" 10.94mm	.421" 10.69mm	316°	56/80 80/56	102° 102°	.010" 0.25mm	.168" 4.26mm	.163" 4.14mm

PEUGEOT 106 '93-'98 on 1.4 1.6 XSi / CITROEN SAXO VTR/VSX/SX 1.4 1.6 Engine Code: TU3M-5M Front bearing size 44.20mm Not suitable for roller type engines Valve lifts quoted using a theoretical Rocker Ratio 1.40:1										
PT11	SPORTS INJECTION <small>12bhp approx increase</small>	2000-6000	.276" 7.01mm	.376" 9.81mm	276°	28/68 68/28	110°	.010" 0.25mm	.050" 1.27mm	N/A
PT12	COMPETITION <small>Carburation</small>	2500-7000	.286" 7.26mm	.390" 9.903mm	310°	49/81 81/49	106°	.010" 0.25mm	.120" 3.05mm	N/A
PT13	RACE <small>Carburation</small>	3000-8000	.300" 7.62mm	.410" 10.41mm	315°	53/82 82/53	104°	.010" 0.25mm	.175" 4.44mm	N/A

PEUGEOT 106/206/306 (SAXO VTR) 1.4 1.6 Roller Type Engine Code: TU3JP-TU5JP Valve lifts quoted using a theoretical Rocker Ratio 1.75:1 Durations quoted at .010" / .25mm checking height										
PT30	SPORTS INJECTION <small>Suitable for 1.4 9bhp approx increase</small>	2000-6500	.230" 5.84mm	.392" 9.95mm	258°	14/64 64/14	115°	.010" 0.25mm	.020" 0.50mm	N/A
PT40	SPORTS INJECTION <small>Suitable for 1.6 11bhp approx increase</small>	2000-6500	.242" 6.14mm	.414" 10.51mm	266°	18/68 68/18	115°	.010" 0.25mm	.030" 0.75mm	N/A
PT41	COMPETITION <small>Modified Injection</small>	2500-7000	.277" 7.03mm	.474" 12.03mm	292°	38/74 80/32	108°	.010" 0.25mm	.120" 3.05mm	N/A

PEUGEOT 106 16V / CITROEN SAXO VTS 16V 1.6 Engine Code: TU5J4 Duration of hydraulic profiles quoted at .004"/.10mm. Mechanical profiles checked at .010"/.25mm checking height										
PT50	SPORTS INJECTION <small>Kit Available</small>	1500-6500	.368" 9.34mm	.368" 9.34mm	262°	21/61 61/21	110° 110°	.000" 0.00mm	.037" 0.94mm	.036" 0.91mm
PT51	SPORTS 'R' <small>Modified Injection</small>	1500-6500	.397" .368" 10.08mm 9.34mm	.397" .368" 10.08mm 9.34mm	262°	21/61 61/21	110° 110°	.000" 0.00mm	.048" 1.22mm	.036" 0.91mm
PT52	COMPETITION <small>Hydraulic</small>	3000-7500	.435" 11.04mm	.435" 11.04mm	278°	31/67 67/31	106° 106°	.000" 0.00mm	.090" 2.28mm	.090" 2.28mm
PT55	COMPETITION <small>Mechanical</small>	3000-7500	.434" .434" 11.02mm 11.02	.424" .424" 10.77mm 10.77mm	290° 290°	39/71 71/39	106° 106°	.010" 0.25mm	.108" 2.75mm	.103" 2.62mm
PT53	COMPETITION <small>Mechanical</small>	3500-8000	.438" 11.12mm	.428" 10.87mm	304°	46/78 78/46	106° 106°	.010" 0.25mm	.141" 3.58mm	.125" 3.17mm
PT54	RACE <small>Mechanical</small>	4000-8500	.450" 11.43mm	.440" 11.17mm	317°	52/85 85/52	106° 106°	.010" 0.25mm	.162" 4.11mm	.155" 3.94mm

CAM FOLLOWER	VALVE SPRING	VALVE SPRING RETAINER	VALVE SPRING KIT	POWER PULLEY	CAM BELT	HEADSTUD KIT	OPTIONAL COMPONENTS
CF97	-	-	-	CA80 CA93	-	-	CA80 - Square tooth cam pulley CA93 - HTD round tooth cam pulley CA98 - HTD round tooth auxiliary pulley S82 - HTD round tooth crank pulley
CF97	-	-	-	CA80 CA93	-	-	
CF97	-	-	-	CA80 CA93	-	-	

Durations quoted at .010" / .25mm checking height							
-	-	-	-	CA31	CB14 CB15	-	CB26 205 1300 RALLYE. CB14 205 / 106 1360 WITH AC. CB15 205 / 106 1360 WITHOUT AC. PT40 - This Cam is for the later 1.6 model with Roller Rockers, (silver rocker cover engine) and will give an impressive 11 bhp. Don't give up if you have the earlier engine type with black rocker cover. The PT11 also gives an impressive 12 bhp. PT30 - The latest addition to the Peugeot range giving an increase of 9bhp with no other modifications.
-	-	-	-	CA31	CB14 CB15	-	
-	-	-	-	CA31	CB14 CB15	-	
-	-	-	-	CA31	CB14 CB15	-	
-	-	-	-	CA31	-	-	
-	-	-	-	CA31	-	-	
-	-	-	VSK40P	CA31	-	-	

CF65	-	-	-	CA72	CB16	HSPT106	CF66 30mm lightweight Mechanical Bucket with shim underneath. The Cam Follower Bore will require machining to accept these. CF93 Mechanical follower std diameter and shim underneath PT50 as tested by one of the leading specialists in Citroen/Peugeot tuning with a pair of Camshafts and an Airfilter Kit, the increase was an incredible 22 bhp, achieved by J A Racing. Kit Car custom grind are also available and can produce in excess of 200bhp.
CF65	-	-	-	CA72	CB16	HSPT106	
CF65	VS51 <small>Single</small>	ST25	VSK33	CA72	CB16	HSPT106	
CF93	VS51 <small>Single</small>	ST25	VSK33	CA72	CB16	HSPT106	
CF93	VS51 <small>Single</small>	ST25	VSK33	CA72	CB16	HSPT106	
CF66	VS51 <small>Single</small>	VRT25	VSK28	CA72	CB16	HSPT106	

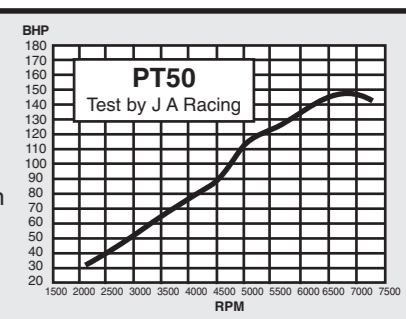

PART No.	APPLICATION <small>See page 3 for key to Camshaft descriptions</small>	POWER BAND	CAM LIFT INLET/EXHAUST	VALVE LIFT INLET/EXHAUST	DURATION INLET/EXHAUST	TIMING FIGURES	INLET TIMING @ FULL LIFT	V/CLEARANCE INLET/EXHAUST	VALVE LIFT INLET	@ TDC EXHAUST
----------	---	------------	---------------------------	-----------------------------	---------------------------	-------------------	-----------------------------	------------------------------	---------------------	------------------

PEUGEOT 205 1.3 / 1360 / CITROEN AXGT 1360 Engine Code: **TU3-5** Front bearing size 42.50mm Valve lifts quoted using a theoretical Rocker Ratio 1.40:1 Durations quoted at .010" / .250mm checking height

PT02	SPORTS <small>12bhp approx increase</small>	2000-6000	.275" 6.98mm	.375" 9.52mm	284°	34/70 70/34	108°	.010" 0.25mm	.070" 1.77mm	N/A -
PT03	COMPETITION	2500-7000	.286" 7.26mm	.390" 9.90mm	310°	49/81 81/49	106°	.010" 0.25mm	.120" 3.05mm	N/A -
PT04	RACE	3000-8000	.300" 7.62mm	.410" 10.41mm	315°	53/82 82/53	104°	.010" 0.25mm	.175" 4.44mm	N/A -

PEUGEOT 205/309/405 1.6 - 1.9 Engine Code: **XU5-9** Direct acting. Durations quoted at .010" / .25mm checking height

PT36 <small>Kit Available</small>	SPORTS INJECTION <small>Suitable for 1.6/1.9 14bhp approx increase</small>	2000-6500	.468" 11.88mm	.458" 11.63mm	.456" 11.58mm	270°	27/63 63/27	106°	.010" 0.25mm	.012" 0.30mm	.077" 1.95mm	N/A -	
PT37	COMPETITION <small>Suitable for 1.6 / 1.9</small>	2250-7000	.470" 11.95mm	.460" 11.95mm		280°	34/66 66/34	106°	.010" 0.25mm		.087" 2.2mm	N/A -	
PT23	RACE <small>Suitable for 1.6</small>	3000-7800	.492" 12.49mm	.482" 12.24mm	.482" 12.24mm	.470" 11.93mm	304° 296°	46/78 74/42	106°	.010" 0.25mm	.012" 0.30mm	.170" 4.31mm	N/A -
PT27	COMPETITION <small>Suitable for 1.9</small>	2500-7000	.492" 12.49mm	.482" 12.24mm	.482" 12.24mm	.470" 11.93mm	304° 296°	46/78 74/42	106°	.010" 0.25mm	.012" 0.30mm	.170" 4.31mm	N/A -
PT28	RACE <small>Suitable for 1.9</small>	3000-7800	.489" 12.42mm	.496" 12.59mm	.479" 12.16mm	.484" 12.29mm	309° 314°	49/80 85/49	106°	.010" 0.25mm	.012" 0.30mm	.177" 4.49mm	N/A -

PEUGEOT 206 1.6 16V / CITROEN C2 1.6 16V Engine Code: **TU5JP4** Duration of hydraulic profiles quoted at .004"/.10mm. Mechanical profiles checked at .010"/.25mm checking height

PT47 <small>Kit Available</small>	SPORTS INJECTION <small>12bhp approx increase</small>	1500-6500	.336" 8.53mm	.336" 8.53mm	240°	10/50 50/10	110° 110°	.000" 0.00mm	.019" 0.48mm	.014" 0.35mm
--------------------------------------	---	-----------	------------------------	------------------------	------	-------------	-----------	------------------------	------------------------	------------------------

PEUGEOT 206 GTi / 307 GTi Engine Code: **EW10JE** Duration of hydraulic profiles quoted at .004"/.10mm. Mechanical profiles checked at .010"/.25mm checking height

PT60	SPORTS INJECTION	2000-6500	.368" 9.34mm	.341" 8.66mm	.368" 9.34mm	.341" 8.66mm	258° 262°	19/59 61/21	110° 110°	.000" 0.00mm	.037" 0.94mm	.031" 0.79mm
------	-------------------------	-----------	------------------------	------------------------	------------------------	------------------------	-----------	-------------	-----------	------------------------	------------------------	------------------------

CAM FOLLOWER	VALVE SPRING	VALVE SPRING KIT	CAM BELT	POWER PULLEY	CONROD BOLT	OPTIONAL COMPONENTS AND COMMENTS
--------------	--------------	------------------	----------	--------------	-------------	----------------------------------

-	-	-	CB14 CB26 CB15	CA31	-	CB07 CB08 205 / 309 1.6i / 1.9i up to '92 Cam Belt. 205 / 309 1.9i post '92 Cam Belt.
-	VS54 Double	VSK23	CB14 CB26 CB15	CA31	-	
-	VS54 Double	VSK23	CB14 CB26 CB15	CA31	-	

CF37	-	-	CB07 CB08	CA31	BEB25-8	PT36 - For all those GTi's that just aren't quick enough. This cam will improve your performance by 14bhp. The kit includes the Gaskets to fit it and shimming is within the Peugeot range. VS52 - Will fit the 205 / 309 / 405 / 306 but will require head modifications to the retainer and platform area
CF37	-	-	CB07 CB08	CA31	BEB25-8	
CF37	VS52 Double	-	CB07 CB08	CA31	BEB25-8	
CF37	VS52 Double	-	CB07 CB08	CA31	BEB25-8	
CF37	VS52 Double	-	CB07 CB08	CA31	BEB25-8	

CF65	-	-	CB16	CA72	-	206 1.6 16v - Citroen C2 1.6 16v use 106 16v for competition equipment
------	---	---	------	------	---	--

-	-	-	CB30	-	-	206GTi Motorsport Equipment - On Application.
---	---	---	------	---	---	---

PART No.	APPLICATION See page 3 for key to Camshaft descriptions	POWER BAND	CAM LIFT INLET/EXHAUST	VALVE LIFT INLET/EXHAUST	DURATION INLET/EXHAUST	TIMING FIGURES	INLET/EXHAUST @ FULL LIFT	V/CLEARANCE INLET/EXHAUST	VALVE LIFT INLET	@ TDC EXHAUST
PEUGEOT 306 2.0 XSi Engine Code: XU10 Direct acting. Durations quoted at .010 / .25mm checking height										
PT46 Kit Available	SPORTS INJECTION <i>10bhp approx increase</i>	2000-6500	.468" 11.88mm	.458" .456" 11.63mm 11.58mm	270°	23/67 67/23	112°	.010" .012" 0.25mm 0.30mm	.049" 1.24mm	N/A
PEUGEOT 306 S16 16V 1993 - 1996 Engine Code: XU10J4 Duration of hydraulic profiles quoted at .004"/.10mm. Mechanical profiles checked at .010"/.25mm checking height										
PT2001 Kit Available	SPORTS INJECTION Hydraulic	1500-6000	.396" 10.06mm	.396" 10.06mm	262°	21/61 61/21	110° 110°	.000" 0.00mm	.058" 1.47mm	.050" 1.27mm
PT2002	SPORTS 'R' Hydraulic	2000-6500	.431" 10.94mm	.431" 10.94mm	264°	20/64 64/20	112° 112°	.000" 0.00mm	.065" 1.65mm	.055" 1.40mm
PT2003	COMPETITION Hydraulic	3000-7000	.426" 10.82mm	.426" 10.82mm	290°	37/73 73/37	108° 108°	.000" 0.00mm	.110" 2.79mm	.092" 2.33mm
PT2005	COMPETITION Mechanical	3000-8000	.472" .444" 11.98mm 11.27mm	.462" .434" 11.73mm 11.02mm	314° 296°	51/83 74/42	106° 106°	.010" 0.25mm	.140" 3.55mm	.122" 3.10mm
PT2006	RACE Mechanical	4500-8500	.472" 11.98mm	.462" 11.73mm	314°	53/81 81/53	104° 104°	.010" 0.25mm	.151" 3.83mm	.146" 3.70mm
PEUGEOT 306 GTi6 16V 1997 on / 406 COUPE Engine Code: XU10J4RS Duration of hydraulic profiles quoted at .004"/.10mm. Mechanical profiles checked at .010"/.25mm checking height										
PT80 Kit Available	SPORTS INJECTION Hydraulic <i>18bhp approx increase</i>	2000-7000	.425" .409" 10.79mm 10.35mm	.425" .409" 10.79mm 10.35mm	264° 252°	20/64 56/16	110° 110°	.000" 0.00mm	.065" 1.65mm	.030" 0.76mm
PT81	SPORTS 'R' Modified Injection	2500-7000	.431" 10.94mm	.431" 10.94mm	264°	20/64 64/20	110° 110°	.000" 0.00mm	.065" 1.65mm	.055" 1.40mm
PT82	COMPETITION Hydraulic	3000-7200	.435" 11.04mm	.435" 11.04mm	278°	31/67 67/31	108° 108°	.000" 0.00mm	.080" 2.03mm	.080" 2.03mm
PT84	COMPETITION Mechanical	3000-8000	.472" .444" 11.98mm 11.27mm	.462" .434" 11.73mm 11.02mm	314° 296°	51/83 74/42	106° 106°	.010" 0.25mm	.140" 3.55mm	.122" 3.10mm
PT85	RACE Mechanical	4500-8500	.472" 11.98mm	.462" 11.73mm	314°	53/81 81/53	104° 104°	.010" 0.25mm	.151" 3.83mm	.146" 3.70mm
PEUGEOT 405 Mi16 16V up to 1992 Engine Code: XU9J4 Duration of hydraulic profiles quoted at .004"/.10mm. Mechanical profiles checked at .010"/.25mm checking height										
PT1601 Kit Available	SPORTS INJECTION Hydraulic <i>12bhp approx increase</i>	1500-6000	.396" 10.06mm	.396" 10.06mm	262°	21/61 61/21	110° 110°	.000" 0.00mm	.058" 1.47mm	.050" 1.27mm
PT1603	COMPETITION Hydraulic	3000-7000	.426" 10.82mm	.426" 10.82mm	290°	37/73 73/37	108° 108°	.000" 0.00mm	.110" 2.79mm	.092" 2.33mm
PT1604	COMPETITION Hydraulic	3500-7500	.427" 10.84mm	.427" 10.84mm	316°	52/84 84/52	106° 106°	.000" 0.00mm	.101" 2.56mm	.101" 2.56mm
PT1605	COMPETITION Mechanical	4000-8000	.438" 11.12mm	.428" 10.87mm	304°	46/78 78/46	106° 106°	.010" 0.25mm	.141" 3.58mm	.125" 3.17mm

CAM FOLLOWER	VALVE SPRING	VALVE SPRING RETAINER	VALVE SPRING KIT	ALLOY POWER PULLEY	CAM BELT	CONROD BOLT	OPTIONAL COMPONENTS
CF37	-	-	-	CA31	-	-	The Valve Spring Kit (VSK12P) contains Valve Springs, Titanium Valve Spring Caps and Platforms. It is designed to be used with mechanical cam follower CF43.
CF55	-	-	-	CA42	CB16	BEB25-8	
CF55	-	-	-	CA42	CB16	BEB25-8	
CF55	-	-	-	CA42	CB16	BEB25-8	
CF43	VS34 Double	VRT12	VSK12P	CA42	CB16	BEB25-8	
CF43	VS34 Double	VRT12	VSK12P	CA42	CB16	BEB25-8	
CF64	-	-	-	CA78	-	-	
CF64	-	-	-	CA78	-	-	
CF64	VS34 Double	VRT15	VSK15P	CA78	-	-	
CF43	VS34 Double	VRT15	VSK15P	CA78	-	-	
CF43	VS34 Double	VRT15	VSK15P	CA78	-	-	
CF55	-	-	-	CA42	CB16 CB31	-	
CF55	-	-	-	CA42	CB16 CB31	-	
CF55	-	-	-	CA42	CB16 CB31	-	
CF43	VS34 Double	VRT12	VSK12P	CA42	CB16 CB31	-	



PART No.	APPLICATION See page 3 for key to Camshaft descriptions	POWER BAND	CAM LIFT INLET/EXHAUST	VALVE LIFT INLET/EXHAUST	DURATION INLET/EXHAUST	TIMING FIGURES	INLET/EXHAUST @ FULL LIFT	V/CLEARANCE INLET/EXHAUST	VALVE LIFT INLET	@ TDC EXHAUST
----------	--	------------	---------------------------	-----------------------------	---------------------------	-------------------	------------------------------	------------------------------	---------------------	------------------

RENAULT CLIO 1.8 16V Engine Code: **F7B** Duration of hydraulic profiles quoted at .004"/.10mm. Mechanical profiles checked at .010"/.25mm checking height

RN1601 Kit Available	SPORTS INJECTION Hydraulic	2000-6500	.396" .363" 10.05mm 9.24mm	.393" .363" 10.05mm 9.24mm	254°	17/57 57/17	110° 110°	.000" 0.00mm	.046" 1.16mm	.037" 0.94mm
RN1602	SPORTS 'R' Hydraulic	2000-6500	.404" 10.26mm	.404" 10.26mm	258°	21/57 57/21	108° 108°	.000" 0.00mm	.067" 1.70mm	.050" 1.27mm
RN1603	COMPETITION Hydraulic	3000-7500	.435" 11.04mm	.435" 11.04mm	278°	31/67 67/31	106° 106°	.000" 0.00mm	.090" 2.28mm	.090" 2.28mm
RN1605	COMPETITION Mechanical	4000-8000	.438" 11.12mm	.428" 10.87mm	304°	46/78 78/46	106° 106°	.010" 0.25mm	.141" 3.58mm	.125" 3.17mm
RN1606	RACE Mechanical	4500-8500	.470" 11.94mm	.460" 11.68mm	324°	58/86 86/58	104° 104°	.010" 0.25mm	.187" 4.75mm	.174" 4.42mm

RENAULT CLIO 2.0 16V Engine Code: **F7R** Duration of hydraulic profiles quoted at .004"/.10mm. Mechanical profiles checked at .010"/.25mm checking height

RN2002 Kit Available	SPORTS INJECTION Hydraulic	2000-6500	.405" .397" 10.28mm 10.08mm	.405" .397" 10.28mm 10.08mm	260°	20/60 60/20	110° 110°	.000" 0.00mm	.058" 1.47mm	.048" 1.22mm
RN2003	SPORTS 'R' Hydraulic	2000-6500	.435" .404" 11.04mm 10.26mm	.435" .404" 11.04mm 10.26mm	278° 258°	31/67 57/21	106° 106°	.000" 0.00mm	.090" 2.28mm	.059" 1.50mm
RN2004	COMPETITION Hydraulic	3000-7500	.451" .435" 11.45mm 11.04mm	.451" .435" 11.45mm 11.04mm	286° 278°	38/68 67/31	105° 105°	.000" 0.00mm	.113" 2.87mm	.094" 2.38mm
RN2005	COMPETITION Mechanical	3000-8000	.472" .444" 11.98mm 11.27mm	.462" .434" 11.73mm 11.02mm	314° 296°	51/83 74/42	106° 106°	.010" 0.25mm	.140" 3.55mm	.122" 3.10mm
RN2006	RACE Mechanical	4500-8500	.472" 11.98mm	.462" 11.73mm	314°	53/81 81/53	104° 104°	.010" 0.25mm	.151" 3.83mm	.146" 3.70mm

RENAULT 5 TURBO Mechanical profiles checked at .016"/.40mm checking height Rocker ratio 1.52:1

RT150	SPORTS	2000-6500	.243" 6.17mm	.335" .333" 8.50mm 8.45mm	252°	14/58 58/14	112°	.010" .012" 0.25mm 0.30mm	.066" 1.67mm	N/A -
RT200	COMPETITION	3000-7000	.269" 6.83mm	.371" .369" 9.42mm 9.37mm	264°	20/64 64/20	112°	.010" .012" 0.25mm 0.30mm	.066" 1.67mm	N/A -
RT300	COMPETITION	3500-7500	.270" 6.83mm	.371" .369" 9.42mm 9.37mm	270°	29/61 61/29	106°	.010" .012" 0.25mm 0.30mm	.105" 2.67mm	N/A -

CAM FOLLOWER	VALVE SPRING	VALVE SPRING RETAINER	VALVE SPRING KIT	ALLOY POWER PULLEY	CAM BELT	CONROD BOLT	OPTIONAL COMPONENTS
--------------	--------------	-----------------------	------------------	--------------------	----------	-------------	---------------------

CF53	-	-	-	CA65	CB20	BEB26-8	RN1601 will increase your 1.8 16 Valve by 16 bhp and can be achieved by regrinding the original camshafts. There is also this option for the 2.0 litre 16 Valve. Part No. RN2002
CF53	-	-	-	CA65	CB20	BEB26-8	
CF53	-	-	-	CA65	CB20	BEB26-8	
CF44	VS34 Double	VRT03	VSK03P	CA65	CB20	BEB26-8	
CF44	VS34 Double	VRT03	VSK03P	CA65	CB20	BEB26-8	
CF53	-	-	-	CA65	CB21	BEB26-8	

CF53	-	-	-	CA65	CB21	BEB26-8
CF53	-	-	-	CA65	CB21	BEB26-8
CF53	-	-	-	CA65	CB21	BEB26-8
CF44	VS34 Double	VRT03	VSK03P	CA65	CB21	BEB26-8
CF44	VS34 Double	VRT03	VSK03P	CA65	CB21	BEB26-8

-	-	-	-	-	-	-
-	-	-	-	-	-	-
-	-	-	-	-	-	-



PART No.	APPLICATION See page 3 for key to Camshaft descriptions	POWER BAND	CAM LIFT INLET/EXHAUST	VALVE LIFT INLET/EXHAUST	DURATION INLET/EXHAUST	TIMING FIGURES	INLET/EXHAUST @ FULL LIFT	V/CLEARANCE INLET/EXHAUST	VALVE LIFT INLET	@ TDC EXHAUST
----------	--	------------	---------------------------	-----------------------------	---------------------------	-------------------	------------------------------	------------------------------	---------------------	------------------

ROVER 3.5 / 3.9 / 4.6 / 5.0 V8 Hydraulic Valve lifts are quoted using a theoretical Rocker Ratio of 1.6:1 Durations quoted at .004"/.10mm.

H180 Kit Available	SPORTS TORQUE <i>22bhp approx increase</i> Suitable for automatics. No valve spring mods but must be checked.	1000-4500	.276" 7.01mm	.441" 11.20mm	262°	23/59 59/23	108°	.000" 0.00mm	.056" 1.42mm	N/A -
H200 Kit Available	MILD ROAD <i>20bhp approx increase</i> Suitable for automatics. No valve spring mods but must be checked.	1000-4500	.269" .283" 6.83mm 7.18mm	.429" .453" 10.89mm 11.50mm	270° 282°	23/67 68/34	112°	.000" 0.00mm	.033" 0.83mm	N/A -
H218 Kit Available	FAST ROAD <i>26bhp approx increase</i> No valve spring mods but must be checked.	1500-5000	.280" .290" 7.11mm 7.36mm	.448" .464" 11.38mm 11.78mm	278° 284°	27/71 74/30	112°	.000" 0.00mm	.065" 1.65mm	N/A -
H214 Kit Available	FAST ROAD <i>30bhp approx increase</i>	1500-5000	.290" .306" 7.36mm 7.77mm	.469" .490" 11.90mm 12.44mm	284° 298°	31/73 78/40	111°	.000" 0.00mm	.062" 1.57mm	N/A -
H224 Kit Available	COMPETITION	2000-5500	.308" .322" 7.82mm 8.17mm	.492" .515" 12.49mm 13.08mm	304° 310°	41/83 86/44	111°	.000" 0.00mm	.085" 2.16mm	N/A -
H234	COMPETITION	2500-6000	.323" .334" 8.20mm 8.48mm	.516" .534" 13.10mm 13.56mm	310°	44/86 86/44	111°	.000" 0.00mm	.110" 2.79mm	N/A -

ROVER 3.5 / 3.9 / 4.6 / 5.0 V8 Mechanical Valve lifts are quoted using a theoretical Rocker Ratio of 1.6:1 Durations quoted at .016"/.40mm.

M228	FAST ROAD Use solid lifters	2500-6000	.304" .308" 7.72mm 7.82mm	.464" .470" 11.78mm 11.94mm	280° 290°	32/68 73/37	108°	.022" 0.55mm	.083" 2.10mm	N/A -
M238	COMPETITION Use solid lifters	2750-7000	.317" 8.05mm	.485" 12.32mm	284° 290°	34/70 73/37	108°	.022" 0.55mm	.107" 2.71mm	N/A -
M248	COMPETITION Use solid lifters	3500-8000	.330" 8.38mm	.506" 12.85mm	300°	43/77 79/41	107°	.022" 0.55mm	.138" 3.5mm	N/A -
M256	RACE Use solid lifters	4000-8250	.338" .350" 8.58mm 8.89mm	.514" .534" 13.05mm 13.56mm	304° 310°	48/76 87/43	104°	.026" 0.66mm	.158" 4.01mm	N/A -

TVR Valve lifts are quoted using a theoretical Rocker Ratio of 1.6:1 Durations quoted at .004"/.10mm.

TVR51	4.0 LITRE ROVER V8 Replacement for OE TVR cam	N/A	.265" 6.75mm	.425" 10.80mm	272° 278°	24/68 71/27	112°	.000" 0.00mm	.060" 1.52mm	N/A -
TVR885	5.0 LITRE ROVER V8 Replacement for OE TVR cam	N/A	.286" .302" 7.27mm 7.69mm	.456" .484" 11.60mm 12.30mm	284° 300°	26/78 86/34	116°	.000" 0.00mm	.051" 1.30mm	N/A -

CAM FOLLOWER	VALVE SPRING	VALVE SPRING RETAINER	POWER PULLEY	CONROD BOLT	HEADSTUD KIT	MAINSTUD KIT	OPTIONAL COMPONENTS
--------------	--------------	-----------------------	--------------	-------------	--------------	--------------	---------------------

CF22	VS44 Single	-	S29	BEBRV60-16	HSRV45	MSRV54	<p>H180 is the best high torque cam around, giving an impressive 22bhp.</p> <p>H218 is the biggest cam without machining spring seats, giving you an increase of 26bhp</p> <p>VS43 Require heads to be machined around the valve guide to achieve the correct fitted length.</p> <p>S29 is a power pulley roll chain kit. To replace the OE type and improve reliability. As used on the TVR Chimaera 5.0</p>
CF22	VS44 Single	-	S29	BEBRV60-16	HSRV45	MSRV54	
CF22	VS44 Single	-	S29	BEBRV60-16	HSRV45	MSRV54	
CF22	VS43 Double	ST47	S29	BEBRV60-16	HSRV45	MSRV54	
CF22	VS43 Double	ST47	S29	BEBRV60-16	HSRV45	MSRV54	
CF22	VS43 Double	ST47	S29	BEBRV60-16	HSRV45	MSRV54	
CF23	VS43 Double	ST47	S29	BEBRV60-16	HSRV45	MSRV54	
CF23	VS43 Double	ST47	S29	BEBRV60-16	HSRV45	MSRV54	
CF23	VS43 Double	ST47	S29	BEBRV60-16	HSRV45	MSRV54	
CF23	VS43 Double	ST47	S29	BEBRV60-16	HSRV45	MSRV54	

CF22	VS44	-	S29	BEBRV60-16	HSRV45	MSRV54
CF22	VS43	ST47	S29	BEBRV60-16	HSRV45	MSRV54

PART No.	APPLICATION <small>See page 3 for key to Camshaft descriptions</small>	POWER BAND	CAM LIFT INLET/EXHAUST	VALVE LIFT INLET/EXHAUST	DURATION INLET/EXHAUST	TIMING FIGURES	INLET TIMING @ FULL LIFT	V/CLEARANCE INLET/EXHAUST	VALVE LIFT INLET	@ TDC EXHAUST
----------	---	------------	---------------------------	-----------------------------	---------------------------	-------------------	-----------------------------	------------------------------	---------------------	------------------

ROVER 'A' Series MINI & METRO When ordering please add the suffix "P", "S" or "M" to denote Pin, Star or Metro oil pump drive.
Valve lifts are quoted using a theoretical Rocker Ratio of 1.28:1 Durations quoted at .016"/.40mm checking height.

MD246 <small>Kit Available</small>	HIGH TORQUE <small>Suitable for Mini stock</small>	1500-6500	.285" <small>7.23mm</small>	.348" <small>8.85mm</small>	252°	18/54 54/18	108°	.016" <small>0.40mm</small>	.055" <small>1.40mm</small>	N/A -
MD256 <small>Kit Available</small>	MILD ROAD <small>Smooth idle characteristics in 1275cc</small>	1000-6000	.263" <small>6.67mm</small>	.320" <small>8.12mm</small>	254°	21/53 53/21	106°	.016" <small>0.40mm</small>	.049" <small>1.24mm</small>	N/A -
MD266 <small>Kit Available</small>	FAST ROAD <small>Smooth idle characteristics in 1275cc</small>	1000-6500	.263" .270" <small>6.67mm 6.85mm</small>	.320" .330" <small>8.12mm 8.37mm</small>	260° 270°	24/56 61/29	106°	.016" <small>0.40mm</small>	.066" <small>1.67mm</small>	N/A -
MD274 <small>Kit Available</small>	SPORTS INJECTION <small>Single point injection</small>	1000-6000	.285" .281" <small>7.23mm 7.13mm</small>	.348" .343" <small>8.85mm 8.71mm</small>	248° 274°	12/56 69/25	112°	.016" <small>0.40mm</small>	.023" <small>0.58mm</small>	N/A -
MD276 <small>Kit Available</small>	FAST ROAD/RALLY <small>Slightly lumpy idle in 1275cc</small>	1500-7000	.293" .315" <small>7.43mm 7.99mm</small>	.360" .388" <small>9.14mm 9.84mm</small>	270° 280°	29/61 66/34	106°	.016" <small>0.40mm</small>	.085" <small>2.16mm</small>	N/A -
MD286 <small>Kit Available</small>	RALLY <small>Slightly lumpy idle in 1275cc</small>	2000-7500	.315" .324" <small>7.99mm 8.22mm</small>	.388" .400" <small>9.84mm 10.15mm</small>	280° 290°	34/66 71/39	106°	.016" <small>0.40mm</small>	.086" <small>2.18mm</small>	N/A -
MD296	RACE <small>Lumpy idle characteristic in 1275cc. Not available in pin drive</small>	3250-8000	.324" .340" <small>8.22mm 8.62mm</small>	.400" .420" <small>10.15mm 10.67mm</small>	290° 300°	39/71 76/44	106°	.016" <small>0.40mm</small>	.110" <small>2.79mm</small>	N/A -
MD310	RACE <small>Rough idle characteristics in 1275cc. Not available in pin drive</small>	4000-8500	.340" <small>8.62mm</small>	.420" <small>10.67mm</small>	310°	49/81 81/49	106°	.016" <small>0.40mm</small>	.145" <small>3.68mm</small>	N/A -
MD315	RACE <small>Not available in pin drive</small>	4500-9000	.347" <small>8.81mm</small>	.428" <small>10.87mm</small>	314°	53/81 81/53	104°	.016" <small>0.40mm</small>	.181" <small>4.60mm</small>	N/A -

Scatter Pattern Cams

Designed by David Vizard, this range will give the ultimate in performance due to the very special design of lobe centre angle and phasing.

274SP	HIGH TORQUE	1500-6500	.285" .281" <small>7.23mm 7.13mm</small>	.348" .343" <small>8.85mm 8.71mm</small>	248° 274°	16/52 71/29	108°	.016" <small>0.40mm</small>	.035" <small>0.89mm</small>	N/A -
286SP	RALLY	2000-7500	.315" .324" <small>7.99mm 8.22mm</small>	.388" .400" <small>9.84mm 10.15mm</small>	280° 290°	34/66 71/39	106°	.016" <small>0.40mm</small>	.086" <small>2.18mm</small>	N/A -
296SP	RACE	3250-8000	.324" .340" <small>8.22mm 8.62mm</small>	.400" .420" <small>10.15mm 10.67mm</small>	290° 300°	39/71 76/44	106°	.016" <small>0.40mm</small>	.110" <small>2.79mm</small>	N/A -
310SP	RACE	4000-8500	.340" <small>8.62mm</small>	.420" <small>10.67mm</small>	310°	49/81 81/49	106°	.016" <small>0.40mm</small>	.145" <small>3.68mm</small>	N/A -

CAM FOLLOWER	VALVE SPRING	VALVE SPRING RETAINER	POWER PULLEY	CONROD BOLT	FLYWHEEL BOLT	HEAD STUD KIT	MAIN STUD KIT	OPTIONAL COMPONENTS
--------------	--------------	-----------------------	--------------	-------------	---------------	---------------	---------------	---------------------

1.5 Ratio Rockers are not recommended for use in engines under 1275cc. All Cams will be slightly hotter when used in 1000cc engines with slight variations in idle characteristics.

CF1	VS49 <small>Single</small>	ST33	S12	BEB6001-8 BEB08-8 BEB1-8	FB900-4 FB900-6	HSA11 HSA11-B HSA9	MSA33 MSA54	S12 Duplex Power Pulley Kit. BEB6001-8 Conrod Bolt 1275 Midget and Cooper 'S' ARP. BEB08-8 Conrod Bolt 850/1098 3/8" ARP. BEB1-8 Conrod Bolt 1300 11/32" ARP. FB900-4 Flywheel Bolt 850 - 1098 3/8" ARP. FB900-6 Flywheel Bolt 1300 3/8" ARP. HSA11 Head Stud Kit 11 Stud and Rocker Studs ARP. HSA11-B Head Stud Kit 11 Stud with Front Bolt and Rocker Studs ARP. HSA9 Head stud Kit 9 Stud and Rocker Stud ARP. MSA33 Main Stud Kit 1098 2" Mains and Cooper 'S' (Shouldered) ARP. MSA54 Mains Stud Kit 1275 (DO not use washers on Mini) ARP SS8 Valve Spring Seat. S52 Duplex Chain. VG01 9/32" Bronze Valves Guides. OP1 Pin Drive Oil Pump. OP2 Star Drive Oil Pump. OP3 Metro Drive Oil Pump. AMS1 ARP Manifold Stud Kit CF95 X/Drilled Lightweight Cam Follower
CF1	VS2 <small>Double</small>	ST33	S12	BEB6001-8 BEB08-8 BEB1-8	FB900-4 FB900-6	HSA11 HSA11-B HSA9	MSA33 MSA54	
CF1	VS2 <small>Double</small>	ST33	S12	BEB6001-8 BEB08-8 BEB1-8	FB900-4 FB900-6	HSA11 HSA11-B HSA9	MSA33 MSA54	
CF1	VS2 <small>Double</small>	ST33	S12	BEB6001-8 BEB08-8 BEB1-8	FB900-4 FB900-6	HSA11 HSA11-B HSA9	MSA33 MSA54	
CF1	VS2 <small>Double</small>	ST33	S12	BEB6001-8 BEB08-8 BEB1-8	FB900-4 FB900-6	HSA11 HSA11-B HSA9	MSA33 MSA54	
CF1	VS39 <small>Double</small>	VRT06 VR9	S12	BEB6001-8 BEB08-8 BEB1-8	FB900-4 FB900-6	HSA11 HSA11-B HSA9	MSA33 MSA54	
CF1	VS39 <small>Double</small>	VRT06 VR9	S12	BEB6001-8 BEB08-8 BEB1-8	FB900-4 FB900-6	HSA11 HSA11-B HSA9	MSA33 MSA54	
CF1	VS39 <small>Double</small>	VRT06 VR9	S12	BEB6001-8 BEB08-8 BEB1-8	FB900-4 FB900-6	HSA11 HSA11-B HSA9	MSA33 MSA54	
CF1	VS39 <small>Double</small>	VRT06 VR9	S12	BEB6001-8 BEB08-8 BEB1-8	FB900-4 FB900-6	HSA11 HSA11-B HSA9	MSA33 MSA54	
CF1	VS49 <small>Single</small>	ST33	S12	BEB6001-8 BEB08-8 BEB1-8	FB900-4 FB900-6	HSA11 HSA11-B HSA9	MSA33 MSA54	

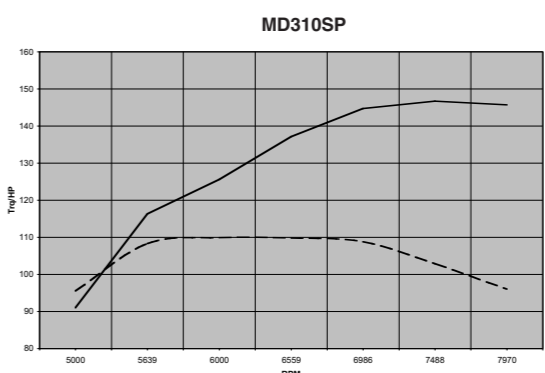
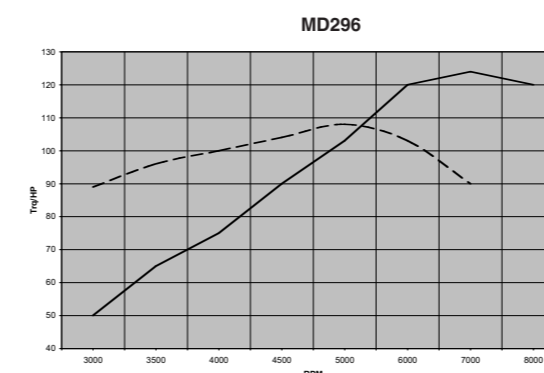
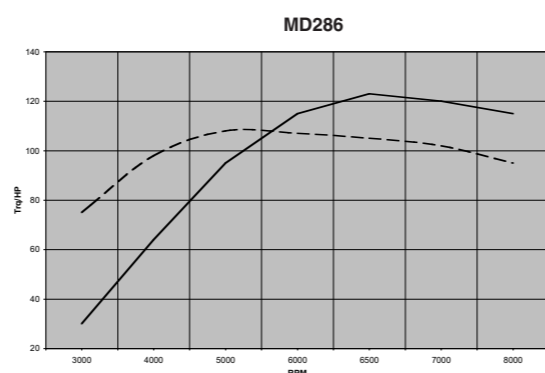
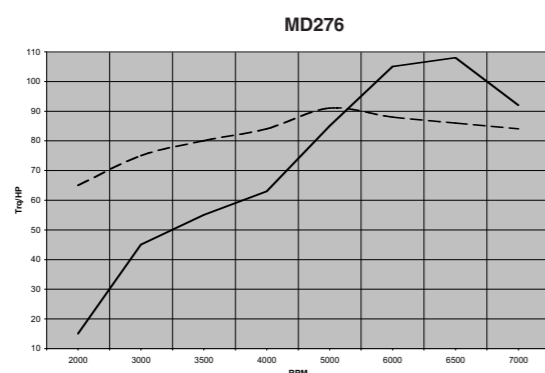
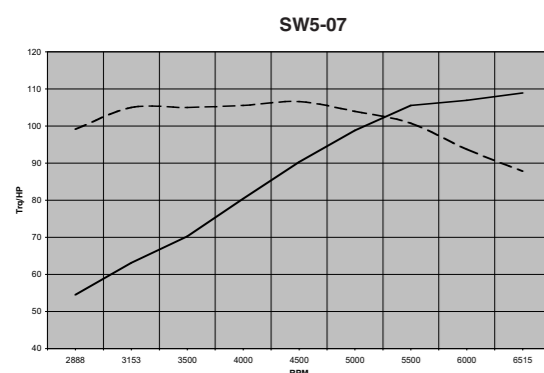

PART No.	APPLICATION See page 3 for key to Camshaft descriptions	POWER BAND	CAM LIFT INLET/EXHAUST	VALVE LIFT INLET/EXHAUST	DURATION INLET/EXHAUST	TIMING FIGURES	INLET TIMING @ FULL LIFT	V/CLEARANCE INLET/EXHAUST	VALVE LIFT INLET	@ TDC EXHAUST
ROVER 'A' Series MINI & METRO When ordering please add the suffix "P", "S" or "M" to denote Pin, Star or Metro oil pump drive. Valve lifts are quoted using a theoretical Rocker Ratio of 1.28:1 Durations quoted at .016"/.40mm checking height.										
NASA 1-99		NASA CLASS 1 1000cc		SPECIFICATIONS AS PER NASA REGULATION BOOK						
MDMS1	BRISCA MINISTOCK	3000-7500	.300" 7.62mm	.368" 9.35mm	254°	21/53 21/53	106°	.016" 0.4mm	.060" 1.52mm	N/A -
MDMS2	SPEDEWORTH MINISTOCK	3000-6500	.291" 7.4mm	.356" 9.05mm	254°	21/53 21/53	106°	.016" 0.4mm	.052" 1.33mm	N/A -
450	500 MILD ROAD and Turbo applications	1500-6000	.263" 6.67mm	.320" 8.12mm	252° 268°	16/56 59/29	110°	.016" 0.40mm	.039" 0.99mm	N/A -
948	567 MILD ROAD	2000-6500	.263" 6.67mm	.320" 8.12mm	252°	16/56 51/21	110°	.016" 0.40mm	.036" 0.91mm	N/A -
550	600 FAST ROAD	2000-7000	.293" 7.43mm	.360" 9.14mm	278° 274°	33/65 63/31	107°	.016" 0.40mm	.078" 1.98mm	N/A -
731	800 FAST ROAD	2500-7000	.263" 6.67mm	.320" 8.12mm	268°	24/64 59/29	110°	.016" 0.40mm	.057" 1.45mm	N/A -
544	643 FAST ROAD-RALLY	2500-7500	.315" 7.99mm	.387" 9.82mm	274°	27/67 67/27	110°	.016" 0.40mm	.073" 1.85mm	N/A -
649	530 RACE	3000-7500	.323" 8.19mm	.397" 10.07mm	287° 281°	43/64 61/40	100°	.016" 0.40mm	.136" 3.45mm	N/A -
STR930	RACE	3000-7500	.327" 8.30mm	.402" 10.22mm	283° 290°	39/64 68/44	102°	.016" 0.40mm	.133" 3.39mm	N/A -
SPRINT 598	RACE	3000-7500	.326" .323" 8.27mm 8.19mm	.401" .397" 10.17mm 10.07mm	304° 282°	52/72 62/41	100°	.016" 0.40mm	.164" 4.16mm	N/A -
SUPER SPRINT 595	RACE	3000-7500	.323" 8.19mm	.397" 10.07mm	306°	53/73 73/53	100°	.016" 0.40mm	.164" 4.16mm	N/A -
895	RACE	3000-7500	.323" 8.19mm	.397" 10.07mm	284° 307°	39/69 76/51	105°	.016" 0.40mm	.118" 3.00mm	N/A -
475	RACE	5000-9000	.371" 9.41mm	.457" 11.60mm	324°	62/82 82/62	100°	.018" 0.46mm	.177" 4.50mm	N/A -

CAM FOLLOWER	VALVE SPRING	VALVE SPRING RETAINER	POWER PULLEY	CONROD BOLT	FLYWHEEL BOLT	HEAD STUD KIT	MAIN STUD KIT	OPTIONAL COMPONENTS
1.5 Ratio Rockers are not recommended for use in engines under 1275cc. All Cams will be slightly hotter when used in 1000cc engines with slight variations in idle characteristics.								
CF1	VS49 Single	ST33	-	-	-	-	-	S12 Duplex Power Pulley Kit. BEB6001-8 Conrod Bolt 1275 Midget and Cooper 'S' ARP. BEB08-8 Conrod Bolt 850/1098 3/8" ARP. BEB1-8 Conrod Bolt 1300 11/32" ARP. FB900-4 Flywheel Bolt 850 - 1098 3/8" ARP. FB900-6 Flywheel Bolt 1300 3/8" ARP. HSA11 Head Stud Kit 11 Stud and Rocker Studs ARP. HSA11-B Head Stud Kit 11 Stud with Front Bolt and Rocker Studs ARP. HSA9 Head stud Kit 9 Stud and Rocker Stud ARP. MSA33 Main Stud Kit 1098 2" Mains and Cooper 'S' (Shouldered) ARP. MSA54 Mains Stud Kit 1275 (DO not use washers on Mini) ARP SS8 Valve Spring Seat. S52 Duplex Chain. VG01 9/32" Bronze Valves Guides. OP1 Pin Drive Oil Pump. OP2 Star Drive Oil Pump. OP3 Metro Drive Oil Pump. AMS1 ARP Manifold Stud Kit CF95 X/Drilled Lightweight Cam Follower
CF1	VS49 Single	ST33	-	-	-	-	-	
CF1	VS2 Double	ST33	S12	BEB6001-8 BEB08-8 BEB1-8	FB900-4 FB900-6	HSA11 HSA11-B HSA9	MSA33 MSA54	
CF1	VS2 Double	ST33	S12	BEB6001-8 BEB08-8 BEB1-8	FB900-4 FB900-6	HSA11 HSA11-B HSA9	MSA33 MSA54	
CF1	VS2 Double	ST33	S12	BEB6001-8 BEB08-8 BEB1-8	FB900-4 FB900-6	HSA11 HSA11-B HSA9	MSA33 MSA54	
CF1	VS2 Double	ST33	S12	BEB6001-8 BEB08-8 BEB1-8	FB900-4 FB900-6	HSA11 HSA11-B HSA9	MSA33 MSA54	
CF1	VS39 Double	VRT06 VR9	S12	BEB6001-8 BEB08-8 BEB1-8	FB900-4 FB900-6	HSA11 HSA11-B HSA9	MSA33 MSA54	
CF1	VS39 Double	VRT06 VR9	S12	BEB6001-8 BEB08-8 BEB1-8	FB900-4 FB900-6	HSA11 HSA11-B HSA9	MSA33 MSA54	
CF1	VS39 Double	VRT06 VR9	S12	BEB6001-8 BEB08-8 BEB1-8	FB900-4 FB900-6	HSA11 HSA11-B HSA9	MSA33 MSA54	
CF1	VS39 Double	VRT06 VR9	S12	BEB6001-8 BEB08-8 BEB1-8	FB900-4 FB900-6	HSA11 HSA11-B HSA9	MSA33 MSA54	



PART No.	APPLICATION <small>See page 3 for key to Camshaft descriptions</small>	POWER BAND	CAM LIFT INLET/EXHAUST	VALVE LIFT INLET/EXHAUST	DURATION INLET/EXHAUST	TIMING FIGURES	INLET TIMING @ FULL LIFT	V/CLEARANCE INLET/EXHAUST	VALVE LIFT INLET	@ TDC EXHAUST
----------	---	------------	---------------------------	-----------------------------	---------------------------	-------------------	-----------------------------	------------------------------	---------------------	------------------

ROVER "B" Series MGB 1600/1800 All cams in this range will fit with no additional machining required but must be checked.

714 <small>Kit Available</small>	MILD ROAD	1800-5800	.264" 6.70mm	.358" 9.08mm	270°	25/65 60/30	110°	.016" 0.40mm	.065" 1.65mm	N/A -
715 <small>Kit Available</small>	FAST ROAD	2000-6000	.264" 6.70mm	.358" 9.08mm	286°	37/69 69/37	106°	.016" 0.40mm	.087" 2.20mm	N/A -
716 <small>Kit Available</small>	RALLY	2500-6500	.277" 7.03mm	.375" 9.56mm	302°	46/76 76/46	105°	.018" .020" 0.46mm 0.50mm	.127" 3.22mm	N/A -

Cams listed below are all high lift/high torque cams with phenominal mid range and top end power. All cams need Kent Special Valve Springs and additional machining may be required

724 <small>Kit Available</small>	HIGH TORQUE	1500-6250	.287" 7.29mm	.391" 9.93mm	270°	31/59 67/23	104°	.016" .018" 0.41mm 0.46mm	.085" 2.16mm	N/A -
717 <small>Kit Available</small>	FAST ROAD	1800-6500	.293" 7.43mm	.394" 10.00mm	280°	37/65 73/27	103°	.022" .024" 0.56mm 0.61mm	.110" 2.79mm	N/A -
718	RALLY	2500-7000	.309" 7.84mm	.416" 10.57mm	290°	42/68 78/32	103°	.022" .024" 0.56mm 0.61mm	.124" 3.15mm	N/A -
719	RACE	3000-7500	.324" 8.22mm	.438" 11.13mm	300°	47/73 83/37	103°	.022" .024" 0.56mm 0.61mm	.150" 3.81mm	N/A -

Scatter Pattern Cams Designed by David Vizard, this range will give the ultimate in performance due to the very special design of lobe centre angle and phasing.

717SP	FAST ROAD	1800-6500	.293" 7.43mm	.394" 10.00mm	280°	37/65 65/35	103°	.022" .024" 0.56mm 0.61mm	.110" 2.79mm	N/A -
718SP	RALLY	2500-7000	.309" 7.84mm	.412" 10.57mm	290°	42/68 70/40	103°	.022" .024" 0.56mm 0.61mm	.124" 3.15mm	N/A -
719SP	RACE	3500-7500	.324" 8.22mm	.438" 11.13mm	300°	47/73 75/45	103°	.022" .024" 0.56mm 0.61mm	.150" 3.81mm	N/A -
720SP	RACE	4000-7500	.323" .331" 8.22mm 8.43mm	.436" .446" 11.079mm 11.32mm	300° 308°	46/74 80/48	104°	.022" .024" 0.56mm 0.61mm	.145" 3.68mm	N/A -
721SP	RACE	4000-8000	.331" .338" 8.43mm 8.60mm	.448" .455" 11.37mm 11.58mm	308° 310°	50/78 81/49	104°	.022" .024" 0.56mm 0.61mm	.171" 4.34mm	N/A -

ROVER "K" Series 1.4 16V Duration of Hydraulic profile quoted at .004" / .10mm. Direct acting ratio 1:1

RK1411 <small>Kit Available</small>	SPORTS INJECTION <small>Hydraulic 10bhp approx increase</small>	2000-6000	.383" 9.72mm	.383" 9.72mm	252°	16/56 56/16	110° 110°	.000" 0.00mm	.035" 0.89mm	.040" 1.01mm
--	--	-----------	-----------------	-----------------	------	-------------	-----------	-----------------	-----------------	-----------------

ROVER "K" Series 1.6 16V Duration of Hydraulic profile quoted at .004" / .10mm. Direct acting ratio 1:1

RK1611 <small>Kit Available</small>	SPORTS INJECTION <small>Hydraulic 12bhp approx increase</small>	2000-6000	.383" 9.72mm	.383" 9.72mm	252°	16/56 56/16	110° 110°	.000" 0.00mm	.035" 0.89mm	.040" 1.01mm
--	--	-----------	-----------------	-----------------	------	-------------	-----------	-----------------	-----------------	-----------------

ROVER "K" Series 1.8 16V Vi-MGF Non VVC Duration of Hydraulic profile quoted at .004" / .10mm Mechanical .010"/.25mm. Direct acting ratio 1:1

RK1811 <small>Kit Available</small>	SPORTS INJECTION <small>Hydraulic 22bhp approx increase</small>	2000-6000	.425" 10.79mm	.425" 10.79mm	258°	19/59 59/19	110° 110°	.000" 0.00mm	.057" 1.45mm	.051" 1.30mm
--	--	-----------	------------------	------------------	------	-------------	-----------	-----------------	-----------------	-----------------

ROVER 220 TURBO 16V Direct acting. Durations quoted at .004" / .10mm checking height

ROV2201	SPORTS	2000-6000	.348" 8.80mm	.348" 8.80mm	252°	16/56 56/16	110° 110°	.000" 0.00mm	.018" 0.46mm	.015" 0.38mm
---------	--------	-----------	-----------------	-----------------	------	-------------	-----------	-----------------	-----------------	-----------------

CAM FOLLOWER	VALVE SPRING	VALVE SPRING RETAINER	POWER PULLEY	CONRAD BOLT	FLYWHEEL BOLT	HEAD STUD KIT	MAIN STUD KIT	OPTIONAL COMPONENTS
--------------	--------------	-----------------------	--------------	-------------	---------------	---------------	---------------	---------------------

Valve lifts are quoted using a theoretical rocker ratio of 1.42:1 Durations quoted @ .016"/.40mm checking height.

CF94 CF4	VS3 Double	ST48	S19	BEB1-8 BEB12-8	FBB716-6	HSB42	MS5B54	715 and 717 Performance Kits are the most popular conversion for the 1800 MGB engine. These kits contain:- Camshaft Cam Followers Valve Springs Valve Spring Retainers
CF94 CF4	VS3 Double	ST48	S19	BEB1-8 BEB12-8	FBB716-6	HSB42	MS5B54	
CF94 CF4	VS3 Double	ST48	S19	BEB1-8 BEB12-8	FBB716-6	HSB42	MS5B54	

CF94 CF4	VS3 Double	ST48	S19	BEB1-8 BEB12-8	FBB716-6	HSB42	MS5B54	CF94 B Series Late Type Cam Follower - Post '71
CF94 CF4	VS3 Double	ST48	S19	BEB1-8 BEB12-8	FBB716-6	HSB42	MS5B54	CF4 B Series Early Type Cam Follower - Pre '71
CF94 CF4	VS27 Double	ST48	S19	BEB1-8 BEB12-8	FBB716-6	HSB42	MS5B54	S19 Duplex Power Pulley Kit
CF94 CF4	VS27 Double	ST48	S19	BEB1-8 BEB12-8	FBB716-6	HSB42	MS5B54	BEB1-8 Conrod Bolt Late 8V MGB 11/32" ARP

Valve lifts are quoted using a theoretical rocker ratio of 1.42:1 Durations quoted @ .016"/.40mm checking height.

CF94 CF4	VS3 Double	ST48	S19	BEB1-8 BEB12-8	FBB716-6	HSB42	MS5B54	BEB12-8 Conrod Bolt Diagonal Split MGB Rods 3/8"x2.0" ARP
CF94 CF4	VS27 Double	ST48	S19	BEB1-8 BEB12-8	FBB716-6	HSB42	MS5B54	MS5B54 Main Stud Kit for 5 Main Bearing (use only to replace studs) ARP
CF94 CF4	VS27 Double	ST48	S19	BEB1-8 BEB12-8	FBB716-6	HSB42	MS5B54	720SP and 721SP Scatter Cams have been developed to improve the top end BHP of the ultimate race engines.
CF94 CF4	VS27 Double	ST48	S19	BEB1-8 BEB12-8	FBB716-6	HSB42	MS5B54	
CF94 CF4	VS27 Double	ST48	S19	BEB1-8 BEB12-8	FBB716-6	HSB42	MS5B54	

ROVER K SERIES COMPETITION see LOTUS ELISE 1.8 Competition Equipment

CF63	VS51 Single	ST69	CA67	BEB37-8	FBKS303	-	-	RK1411 - will improve performance by 10 BHP RK1611 - will improve performance by 12 BHP RK1811 - will improve your underpowered 1.8K series of 120 BHP to an impressive 145 BHP . Then a performance exhaust and modified ECU can boost it to 152 BHP .
CF63	VS51 Single	ST69	CA67	BEB37-8	FBKS303	-	-	
CF63	VS51 Single	ST69	CA67	BEB37-8	FBKS303	-	-	

PART No.	APPLICATION <small>See page 3 for key to Camshaft descriptions</small>	POWER BAND	CAM LIFT INLET/EXHAUST	VALVE LIFT INLET/EXHAUST	DURATION INLET/EXHAUST	TIMING FIGURES	INLET/EXHAUST @ FULL LIFT	V/CLEARANCE INLET/EXHAUST	VALVE LIFT INLET	@ TDC EXHAUST
SEAT 2.0 8Valve Cupra Sport / Toledo Direct acting. Durations quoted at .004" / .10mm checking height										
SE1H <small>Kit Available</small>	SPORTS INJECTION <small>10bhp approx increase Carburation & injection. No piston mods. Suitable for Catalyst</small>	1500-6000	.440" 11.17mm	.440" 11.17mm	266°	21/65 65/21	112°	.000" 0.00mm	.055" 1.40mm	N/A -
SE2H <small>Kit Available</small>	SPORTS 'R' <small>12bhp approx increase Carburation & injection. No piston mods.</small>	2000-6500	.446" 11.32mm	.446" 11.32mm	270°	25/65 65/25	110°	.000" 0.00mm	.061" 1.55mm	N/A -
SEAT 2.0 16V Ibiza / Cordoba / Toledo Direct acting. Durations quoted at .004" / .10mm checking height										
SE2001 <small>Kit Available</small>	SPORTS INJECTION <small>17bhp approx increase</small>	2000-6500	.431" 10.94mm	.431" 10.94mm	264°	22/64 64/22	110° 110°	.000" 0.00mm	.065" 1.65mm	.056" 1.42mm
SUBARU Impreza Turbo Version 4 Direct acting. Durations quoted @ .004" / .10mm checking height. .010" / .25mm mechanical										
SUB01	SPORTS 'R' <small>Hydraulic road</small>	2000-6000	.337" 8.55mm	.337" 8.55mm	262°	19/63 63/19	112° 112°	.000" 0.00mm	.018" 0.45mm	.018" 0.45mm
SUB03	COMPETITION <small>Mechanical rally</small>	2500-7000	.366" 9.29mm	.356" 9.04mm	260°	20/60 60/20	110° 110°	.010" 0.25mm	.051" 1.29mm	.046" 1.17mm
SUBARU Impreza Turbo Version 5 & 6 Direct acting. Durations quoted @ .004" / .10mm checking height. .010" / .25mm mechanical										
SUB04	COMPETITION <small>Mechanical</small>	2500-7000	.407" 10.33mm	.397" 10.08mm	272°	26/66 66/26	110° 110°	.010" 0.25mm	.049" 1.24mm	.045" 1.14mm
TOYOTA 1.8 2ZZ-GE VVTL-i Valve lifts are quoted using a theoretical Rocker Ratio of 1.7:1 and duration quoted as Vtec valve period										
LEVVT01	SPORT <small>OE Replacement</small> NEW	2000-8500	6.7mm 6.0mm	11.2mm 10.0mm	292° 276°	VVT	Manufacturer's Timing Marks	0.15mm 0.25mm	N/A -	N/A -
LEVVT02	SPORTS R NEW	2000-8500	7.0mm 6.35mm	11.75mm 10.55mm	300° 285°	VVT	Manufacturer's Timing Marks	0.15mm 0.25mm	N/A -	N/A -
TOYOTA 1200 / 1300 Starlet RWD 1978-1989 Valve lifts are quoted using a theoretical Rocker Ratio of 1.52:1 durations quoted at .016" / .40mm checking height										
T125	COMPETITION	2500-6500	.293" 7.43mm	.423" .421" 10.74mm 10.69mm	280°	37/63 73/27	103°	.022" .024" 0.56mm 0.61mm	.112" 2.84mm	N/A -
T126	RACE	3000-7000	.309" 7.84mm	.447" .445" 11.35mm 11.30mm	290°	42/68 78/32	103°	.022" .024" 0.56mm 0.61mm	.138" 3.50mm	N/A -
TOYOTA 16V D.O.H.C. 4AGE MR2 & COROLLA 1.6GT Direct Acting. Durations quoted at .010" / .25mm checking height										
T1602	SPORTS	2000-7000	.313" 7.95mm	.303" 7.70mm	272°	26/66 66/26	110° 110°	.010" 0.25mm	.034" 0.86mm	.032" 0.81mm
T1603	COMPETITION <small>Track day with modified injection</small> NEW	2000-7000	.330" 8.40mm	.320" 8.15mm	282°	33/69 69/33	108° 108°	.010" 0.25mm	.065" 1.65mm	.053" 1.35mm
T1604	COMPETITION	3000-7500	.346" 8.79mm	.336" 8.54mm	290°	37/73 73/37	108° 108°	.010" 0.25mm	.084" 2.13mm	.076" 1.93mm
T1606	RACE	4000-8000	.352" 8.94mm	.342" 8.69mm	306°	48/78 78/48	105° 105°	.010" 0.25mm	.109" 2.76mm	.105" 2.66mm

CAM FOLLOWER	VALVE SPRING	POWER PULLEY	CAM BELT	CONROD BOLT	HEAD STUD KIT	FLYWHEEL BOLT	MAIN STUD KIT	OPTIONAL COMPONENTS
CF38	-	CA32	CB25	-	-	-	-	
CF38	-	CA32	CB25	-	-	-	-	
CF62	-	S69 CA68	CB23	-	-	-	-	S69 Power pulley for internal gears CA68 Power pulley for belt drive
-	-	-	-	-	-	-	-	
-	-	-	-	-	-	-	-	
-	-	-	-	-	-	-	-	
-	-	-	-	-	-	-	-	
-	-	-	-	-	-	-	-	
-	VS35 Single	S63	-	-	-	-	-	
-	VS35 Single	S63	-	-	-	-	-	
-	-	CA79	CB22	BEB27-8	HST4201	FBT2802	MST5403	CF70 are lightweight Cam Followers with the shim underneath, the standard bucket with the shim on top and can fail at high rpm.
CF70	-	CA79	CB22	BEB27-8	HST4201	FBT2802	MST5403	
CF70	-	CA79	CB22	BEB27-8	HST4201	FBT2802	MST5403	
CF70	-	CA79	CB22	BEB27-8	HST4201	FBT2802	MST5403	



PART No.	APPLICATION See page 3 for key to Camshaft descriptions	POWER BAND	CAM LIFT INLET/EXHAUST	VALVE LIFT INLET/EXHAUST	DURATION INLET/EXHAUST	TIMING FIGURES	INLET/EXHAUST @ FULL LIFT	V/CLEARANCE INLET/EXHAUST	VALVE LIFT INLET	@ TDC EXHAUST
----------	--	------------	---------------------------	-----------------------------	---------------------------	-------------------	------------------------------	------------------------------	---------------------	------------------

TRIUMPH 1200 / 1300 / 1500 Valve lifts are quoted using a theoretical Rocker Ratio of 1.52:1 Durations quoted at .016" / .40mm checking height.

TH12 Kit Available	HIGH TORQUE	1500-6500	.287" 7.29mm	.420" .418" 10.66mm 10.61mm	270°	31/59 67/23	104°	.016" .018" 0.41mm 0.46mm	.090" 2.28mm	N/A -
TH2 Kit Available	FAST ROAD	2500-6500	.261" 6.62mm	.382" .378" 9.69mm 9.59mm	295°	39/76 76/39	108°	.014" .018" 0.36mm 0.46mm	.086" 2.18mm	N/A -
TH3 Kit Available	RALLY	2500-6800	.282" 7.15mm	.412" 10.47mm	284°	34/70 70/34	108°	.016" 0.41mm	.098" 2.48mm	N/A -

Camshafts listed below are all high lift/high torque cams with phenomenal mid-range and top end power.

TH5 Kit Available	FAST ROAD	2200-7000	.293" 7.44mm	.423" .421" 10.74mm 10.69mm	280°	37/63 73/27	103°	.022" .024" 0.56mm 0.61mm	.112" 2.84mm	N/A -
TH6	RALLY	3000-7500	.309" 7.84mm	.447" .445" 11.35mm 11.30mm	290°	42/68 78/32	103°	.022" .024" 0.56mm 0.61mm	.138" 3.50mm	N/A -
TH7	RACE	3750-8000	.324" 8.22mm	.470" .468" 11.93mm 11.88mm	300°	47/73 83/37	103°	.022" .024" 0.56mm 0.61mm	.169" 4.29mm	N/A -

TRIUMPH TR4 2.2 Valve lifts are quoted using a theoretical Rocker Ratio of 1.52:1 durations quoted at .016" / .40mm checking height.

TR4-4	HIGH TORQUE Touring specification	NEW 1500-6500	.287" 7.29mm	.420" .418" 10.66mm 10.61mm	270°	31/59 67/23	104°	.016" .018" 0.41mm 0.46mm	.090" 2.28mm	N/A -
TR4-5	FAST ROAD	2200-7000	.293" 7.44mm	.423" .421" 10.74mm 10.69mm	280°	37/63 73/27	103°	.022" .024" 0.56mm 0.61mm	.112" 2.84mm	N/A -
TR4-6	RALLY	3000-7500	.309" 7.84mm	.447" .445" 11.35mm 11.30mm	290°	42/68 78/32	103°	.022" .024" 0.56mm 0.61mm	.138" 3.50mm	N/A -
TR4-7	RACE	3750-8000	.324" 8.22mm	.470" .468" 11.93mm 11.88mm	300°	47/73 83/37	103°	.022" .024" 0.56mm 0.61mm	.169" 4.29mm	N/A -

TRIUMPH 2000 / 2.5 6 Cylinder Valve lifts are quoted using a theoretical Rocker Ratio of 1.52:1 durations quoted at .016" / .40mm checking height.

TH12-6 Kit Available	HIGH TORQUE	1500-6500	.287" 7.29mm	.420" .418" 10.66mm 10.61mm	270°	31/59 67/23	104°	.016" .018" 0.41mm 0.46mm	.090" 2.28mm	N/A -
TH2-6 Kit Available	FAST ROAD	2500-6500	.261" 6.62mm	.382" .378" 9.69mm 9.59mm	295°	39/76 76/39	108°	.014" .018" 0.36mm 0.46mm	.086" 2.18mm	N/A -
TH5-6	FAST ROAD	2200-7000	.293" 7.44mm	.423" .421" 10.74mm 10.69mm	280°	37/63 73/27	103°	.022" .024" 0.56mm 0.61mm	.112" 2.84mm	N/A -
TH6-6	RALLY	3000-7500	.309" 7.84mm	.447" .445" 11.35mm 11.30mm	290°	42/68 78/32	103°	.022" .024" 0.56mm 0.61mm	.138" 3.50mm	N/A -
TH7-6	RACE	3750-8000	.324" 8.22mm	.470" .468" 11.93mm 11.88mm	300°	47/73 83/37	103°	.022" .024" 0.56mm 0.61mm	.169" 4.29mm	N/A -

CAM FOLLOWER	VALVE SPRING	POWER PULLEY	CAM BELT	CONROD BOLT	HEAD STUD KIT	FLYWHEEL BOLT	MAIN STUD KIT	OPTIONAL COMPONENTS
--------------	--------------	--------------	----------	-------------	---------------	---------------	---------------	---------------------

CF24	VS15 Double	S72 S73	-	BEB15-8	HST425-10	FBT716-4	MST54	
CF24	VS15 Double	S72 S73	-	BEB15-8	HST425-10	FBT716-4	MST54	
CF24	VS15 Double	S72 S73	-	BEB15-8	HST425-10	FBT716-4	MST54	

All cams need Kent Special Valve Springs and additional machining may be required.

CF24	VS15 Double	S72 S73	-	BEB15-8	HST425-10	FBT716-4	MST54	HST425-10 Head Stud Kit 10 stud 1300/1500cc S72 Power Pulley Kit 1300 4cyl early S73 Power Pulley Kit 1300/1500 4cyl late S74 Power Pulley Kit TR2, 3, 4 S75 Power Pulley Kit 2.0/2.5 6cyl
CF24	VS15 Double	S72 S73	-	BEB15-8	HST425-10	FBT716-4	MST54	
CF24	VS15 Double	S72 S73	-	BEB15-8	HST425-10	FBT716-4	MST54	

-	VS52 Double	S74	-	BEB20-8	HSTR4	-	-	The Pulley kits consist of Crank Sprocket, Duplex Endless Timing Chain and adjustable Cam Sprocket. VS52 can be used on the TR4 but machining to the retainer and spring seating area may be required.
-	VS52 Double	S74	-	BEB20-8	HSTR4	-	-	
-	VS52 Double	S74	-	BEB20-8	HSTR4	-	-	
-	VS52 Double	S74	-	BEB20-8	HSTR4	-	-	

CF25	VS17 Double	S75	-	BEB15-12	HSGT6	-	-
CF25	VS17 Double	S75	-	BEB15-12	HSGT6	-	-
CF25	VS17 Double	S75	-	BEB15-12	HSGT6	-	-
CF25	VS17 Double	S75	-	BEB15-12	HSGT6	-	-
CF25	VS17 Double	S75	-	BEB15-12	HSGT6	-	-

PART No.	APPLICATION <small>See page 3 for key to Camshaft descriptions</small>	POWER BAND	CAM LIFT INLET/EXHAUST	VALVE LIFT INLET/EXHAUST	DURATION INLET/EXHAUST	TIMING FIGURES	INLET TIMING @ FULL LIFT	V/CLEARANCE INLET/EXHAUST	VALVE LIFT INLET	@ TDC EXHAUST
----------	---	------------	---------------------------	-----------------------------	---------------------------	-------------------	-----------------------------	------------------------------	---------------------	------------------

VAUXHALL / OPEL 1300 ASTRA, KADETT, NOVA, CORSA Hydraulic Valve Lifts are quoted using a theoretical Rocker Ratio of 1.69:1 Durations quoted at .004" / .10mm checking height

AST11 <small>Kit Available</small>	SPORTS <i>8bhp approx increase</i> Hydraulic	1500-5500	.240" 6.09mm	.405" 10.30mm	262°	25/57 57/25	106°	.000" 0.00mm	N/A -	N/A -
AST1 <small>Kit Available</small>	SPORTS <i>10bhp approx increase</i> Hydraulic	2000-6000	.246" 6.24mm	.415" 10.55mm	270°	29/61 61/29	106°	.000" 0.00mm	N/A -	N/A -
AST2 <small>Kit Available</small>	SPORTS 'R' <i>12bhp approx increase</i> Hydraulic	3000-7000	.240" 6.09mm	.405" 10.30mm	290°	36/74 74/36	109°	.000" 0.00mm	N/A -	N/A -
AST3 <small>Kit Available</small>	COMPETITION Hydraulic	2500-7000	.295" 7.49mm	.498" 12.66mm	280°	34/66 66/34	106°	.000" 0.00mm	N/A -	N/A -

Mechanical valve lifts are quoted using a theoretical Rocker Ratio of 1.69:1 Durations quoted at .010" / .25mm checking height

AST17	COMPETITION <small>Mechanical - High torque for loose surface use</small>	2800-7500	.274" 6.95mm	.446" 11.36mm	284°	37/67 77/27	105°	.010" 0.25mm	.120" 3.05mm	N/A -
AST18	COMPETITION <small>Mechanical - Where power is more important than torque</small>	3250-8000	.305" 7.75mm	.498" 12.66mm	304°	44/80 80/44	108°	.010" 0.25mm	.145" 3.68mm	N/A -
AST19	RACE <small>Mechanical - Tarmac use only</small>	4000-8500	.294" 7.46mm	.479" 12.19mm	313°	48/85 85/48	108°	.010" 0.25mm	.155" 3.94mm	N/A -

VAUXHALL / OPEL 1400 and 1600 Post 89 CAVALIER, VECTRA, ASTRA, KADETT, NOVA, CORSA Hydraulic Valve Lifts are quoted using a theoretical Rocker Ratio of 1.69:1

NVO51 <small>Kit Available</small>	SPORTS INJECTION <small>Hydraulic Injection Catalyst 8bhp approx increase</small>	1500-5500	.256" 6.50mm	.432" 10.98mm	262°	17/65 65/17	114°	.000" 0.00mm	N/A -	N/A -
NVO52 <small>Kit Available</small>	SPORTS 'R' <i>10bhp approx increase</i> <small>Hydraulic Injection with adjustable fuel regulator</small>	1500-5500	.265" 6.73mm	.447" 11.37mm	262°	25/57 57/25	106°	.000" 0.00mm	N/A -	N/A -
NVO61 <small>Kit Available</small>	SPORTS 'R' <i>12bhp approx increase</i> <small>Injection Recommended with adjustable fuel regulator</small>	2000-6000	.272" 6.90mm	.459" 11.67mm	270°	30/60 60/30	105°	.000" 0.00mm	N/A -	N/A -
NVO62 <small>Kit Available</small>	SPORTS INJECTION <i>10bhp approx increase</i> <small>Hydraulic Injection / catalyst camshaft</small>	1500-6000	.272" 6.90mm	.459" 11.67mm	270°	21/69 69/21	114°	.000" 0.00mm	N/A -	N/A -
NVO63 <small>Kit Available</small>	COMPETITION Hydraulic	3000-7000	.275" 6.98mm	.464" 11.80mm	312°	52/80 80/52	104°	.000" 0.00mm	N/A -	N/A -

Mechanical valve lifts are quoted using a theoretical Rocker Ratio of 1.69:1 Durations quoted at .010" / .25mm checking height

AST28	SUPERSPORTS STOCK ROD	3250-8000	.281" 7.31mm	.464" 11.80mm	303°	45/78 78/45	106°	.010" 0.25mm	.135" 3.43mm	N/A -
NVO82	COMPETITION	3250-7750	.314" 7.97mm	.514" 13.05mm	308°	46/82 82/46	108°	.010" 0.25mm	.145" 3.68mm	N/A -
NVO83	RACE	4000-8500	.312" 7.92mm	.510" 12.95mm	316°	52/83 83/52	105°	.010" 0.25mm	.160" 4.06mm	N/A -

VAUXHALL / OPEL 1600 up to 89 and 1800 CAVALIER, VECTRA, ASTRA, KADETT Hydraulic Valve Lifts are quoted using a theoretical Rocker Ratio of 1.69:1

AST20	SPORTS INJECTION <i>14bhp approx increase</i> Hydraulic Injection	2000-6000	.295" 7.49mm	.498" 12.64mm	272°	22/66 66/22	110°	.000" 0.00mm	N/A -	N/A -
AST21	SPORTS 'R' <i>16bhp approx increase</i> <small>Hydraulic Use with Adj. Pressure regulator or Carbs.</small>	2000-6000	.295" 7.49mm	.498" 12.64mm	272°	28/64 64/28	108°	.000" 0.00mm	N/A -	N/A -
AST22	COMPETITION Hydraulic	3000-7000	.275" 6.98mm	.464" 11.80mm	312°	52/80 80/52	104°	.000" 0.00mm	N/A -	N/A -

CAM FOLLOWER	VALVE SPRING	VALVE SPRING KIT	MECHANICAL ADJUSTERS	COMPETITION LASH CAPS	POWER PULLEY	CAM BELT	CONROD BOLT	HEADSTUD KIT	MAINSTUD KIT	OPTIONAL COMPONENTS
--------------	--------------	------------------	----------------------	-----------------------	--------------	----------	-------------	--------------	--------------	---------------------

CF20	-	-	-	-	CA23	CB04	BEB23-8	HSV2084	-	HSV2084 ARP Stud and Nut Head Stud Kit.
CF20	VS31 <small>Single</small>	-	-	-	CA23	CB04	BEB23-8	HSV2084	-	
CF20	VS31 <small>Single</small>	-	-	S64	CA23	CB04	BEB23-8	HSV2084	-	
CF20	VS30 <small>Single</small>	-	-	S64	CA23	CB04	BEB23-8	HSV2084	-	

CF20	VS30 <small>Single</small>	-	S36	S64	CA23	CB04	BEB23-8	HSV2084	-	AST28 The ultimate cam for the 1400 stock rods as used by many top engine builders with great results.
CF20	VS30 <small>Single</small>	-	S36	S64	CA23	CB04	BEB23-8	HSV2084	-	
CF20	VS30 <small>Single</small>	-	S36	S64	CA23	CB04	BEB23-8	HSV2084	-	

Durations quoted at .004" / .10mm checking height

CF20	-	-	-	-	CA55	CB17 CB18	BEB24-8	HSV2084	-	S36 Mechanical Adjusters Straight forward installation tappet adjustment to be set with cam carrier removed.
CF20	-	-	-	-	CA55	CB17 CB18	BEB24-8	HSV2084	-	
CF20	VS31 <small>Single</small>	-	-	-	CA55	CB17 CB18	BEB24-8	HSV2084	-	
CF20	VS31 <small>Single</small>	-	-	-	CA55	CB17 CB18	BEB24-8	HSV2084	-	

CF20	-	-	S36	S64	CA55	CB17 CB18	BEB24-8	HSV2084	-	CF20 Cam Followers Cam Followers to be used with S36 and hydraulic cams
CF20	-	VSK45P	S36	S64	CA55	CB17 CB18	BEB24-8	HSV2084	-	
CF20	-	VSK45P	S36	S64	CA55	CB17 CB18	BEB24-8	HSV2084	-	

Durations quoted at .004" / .10mm checking height

CF20	-	-	-	-	CA30	CB05	-	-	-	CB17 Cam Belt 1.4/1.6 up to '91 CB18 Cam Belt 1.4/1.6 post '91
CF20	-	-	-	-	CA30	CB05	-	-	-	
CF20	-	-	-	-	CA30	CB05	-	-	-	

NV062 This Cam kit includes Cam, Cam Followers, Valve Springs, Valve Spring Retainers and Gasket fitment kit. The improvement with this kit is **10bhp** and idle characteristics are smooth.

With the **Vauxhall 'J' series** engine, if it has done excessive mileage we suggest the hydraulic pedestal is changed with new genuine parts.

PART No.	APPLICATION <small>See page 3 for key to Camshaft descriptions</small>	POWER BAND	CAM LIFT INLET/EXHAUST	VALVE LIFT INLET/EXHAUST	DURATION INLET/EXHAUST	TIMING FIGURES	INLET EXHAUST @ FULL LIFT	V/CLEARANCE INLET/EXHAUST	VALVE LIFT INLET	@ TDC EXHAUST
VAUXHALL / OPEL 16 Valve 2000 upto 1992										
<small>Durations of hydraulic profiles quoted at .004" / .10mm. Mechanical profiles checked at .010" / .25mm checking height Direct acting ratio 1:1</small>										
AST1612 <small>Kit Available</small>	SPORTS INJECTION <small>Hydraulic 16bhp approx increase</small>	1500-6500	.397" 10.08mm	.397" 10.08mm	260°	20/60 60/20	110° 110°	.000" 0.00mm	.048" 1.22mm	.048" 1.22mm
AST1603 <small>Kit Available</small>	COMPETITION <small>Hydraulic. High Torque - Loose surface. Rally</small>	3000-7500	.435" 11.04mm	.435" 11.04mm	278°	31/67 67/31	108° 108°	.000" 0.00mm	.080" 2.03mm	.080" 2.03mm
AST1608 <small>Kit Available</small>	COMPETITION <small>Hydraulic. Torque - BHP. Autograss Combination</small>	3250-7750	.445" .435" 11.30mm 11.04mm	.445" .435" 11.30mm 11.04mm	290° 278°	37/73 67/31	108° 108°	.000" 0.00mm	.113" 2.87mm	.080" 2.03mm
AST1613 <small>Kit Available</small>	COMPETITION <small>Hydraulic. Midrange - Loose surface. Autograss Class 3</small>	3500-8000	.445" 11.30mm	.445" 11.30mm	290°	37/73 69/41	108° 108°	.000" 0.00mm	.113" 2.87mm	.107" 2.71mm
AST1623 <small>Kit Available</small>	COMPETITION <small>Hydraulic. Ultimate Hard Surface Tarmac. Rally</small>	3750-8000	.450" .445" 11.43mm 11.30mm	.450" .445" 11.43mm 11.30mm	304° 290°	44/80 69/41	108° 108°	.000" 0.00mm	.135" 3.43mm	.107" 2.71mm
AST1614	COMPETITION <small>Autograss / Rally Mechanical</small>	3000-8000	.455" 11.55mm	.445" 11.30mm	304°	46/78 78/46	106° 106°	.010" 0.25mm	.120" 3.04mm	.112" 2.84mm
AST1625	RACE <small>Mechanical National Hot Rod</small>	4000-8000	.486" 12.35mm	.476" 12.10mm	296° 296°	42/74 70/46	106° 102°	.010" 0.25mm	.135" 3.45mm	.150" 3.80mm
AST1626	COMPETITION <small>Ultimate Rally Mechanical</small>	4000-8000	.510" .486" 12.95mm 12.35mm	.500" .476" 12.70mm 12.10mm	306° 296°	51/75 74/42	102° 106°	.010" 0.25mm	.175" 4.45mm	.131" 3.33mm
AST1616	RACE <small>Mechanical</small>	4500-8500	.472" .444" 11.98mm 11.27mm	.462" .434" 11.73mm 11.02mm	314° 296°	51/83 74/42	106° 106°	.010" 0.25mm	.140" 3.55mm	.122" 3.10mm

VAUXHALL / OPEL 2000 8 Valve CAVALIER, VECTRA, CARLTON, ASTRA, KADETT, NOVA, CORSA, CALIBRA										
<small>Hydraulic Valve Lifts are quoted using a theoretical Rocker Ratio of 1.69:1 Durations quoted at .004" / .10mm checking height</small>										
AST52 <small>Kit Available</small>	SPORTS INJECTION <small>Hydraulic Injection catalyst 12bhp approx increase</small>	1000-6000	.290" 7.36mm	.490" 12.44mm	262°	21/61 61/21	110°	.000" 0.00mm	N/A	N/A
AST14 <small>Kit Available</small>	SPORTS INJECTION 14bhp approx increase <small>Hydraulic. For use on catalyst engines. Adjustable Fuel Regulator recommended.</small>	1000-6000	.295" 7.49mm	.498" 12.64mm	272°	26/66 66/26	110°	.000" 0.00mm	N/A	N/A
AST15 <small>Kit Available</small>	SPORTS 'R' 20bhp approx increase <small>Hydraulic. For use on catalyst engines. Adjustable Fuel Regulator recommended.</small>	2000-6500	.295" 7.49mm	.498" 12.64mm	272°	31/61 61/31	105°	.000" 0.00mm	N/A	N/A
AST16 <small>Kit Available</small>	COMPETITION Hydraulic. For use with - <small>Carburetors or programmable injection</small>	3000-7000	.275" 6.98mm	.464" 11.80mm	312°	52/80 80/52	104°	.000" 0.00mm	N/A	N/A

IMPORTANT - Read notes Re. components required to fit the next three cams in this range										
<small>Mechanical Valve Lifts are quoted using a theoretical Rocker Ratio of 1.69:1 Durations quoted at .010" / .25mm checking height</small>										
AST30	COMPETITION Mechanical. Ultimate High <small>Torque Camshaft for Injection or Carburetors</small>	1000-7000	.290" 7.36mm	.473" 12.02mm	266°	20/60 60/20	110°	.010" 0.25mm	.090" 2.28mm	N/A
AST31	COMPETITION Mechanical. Loose surface <small>Camshaft. Excellent mid range on Carburetors</small>	3000-8000	.309" .305" 7.84mm 7.74mm	.505" .498" 12.82mm 12.66mm	304° 292°	42/82 76/36	110°	.010" 0.25mm	.145" 3.68mm	N/A
AST32	RACE <small>Mechanical. Ultimate Power Camshaft</small>	4500-8750	.310" 7.87mm	.507" 12.88mm	322°	55/87 87/55	106°	.010" 0.25mm	.170" 4.32mm	N/A

CAM FOLLOWER	VALVE SPRING	VALVE SPRING RETAINER	VALVE SPRING KIT	ALLOY POWER PULLEY	CAM BELT	CONROD BOLT	FLYWHEEL BOLT	HEADSTUD KIT	MAINSTUD KIT	OPTIONAL COMPONENTS
CF54	-	-	-	CA64	CB11	BEB18-8	FBV985-8	HSV4301	MSV5401	VSK25P Single Valve Spring Kit Including ST55 VSK01P Double Valve Spring kit including VRT01 CA66 Low Noise Belt Alloy Power Pulley FBV985-8 12 point for all Flywheels Kent Cams manufacture the ultimate range of cams to suit all applications Contact our technical team to discuss your requirements. Kent Cams Vauxhall 16V powered cars have probably won more races than all the other cam manufacturers put together - call for the latest information or visit www.kentcams.com .
CF54	VS55 <small>Single</small>	ST55	VSK25P	CA64	CB11	BEB18-8	FBV985-8	HSV4301	MSV5401	
CF54	VS55 <small>Single</small>	ST55	VSK25P	CA64	CB11	BEB18-8	FBV985-8	HSV4301	MSV5401	
CF54	VS55 <small>Single</small>	ST55	VSK25P	CA64	CB11	BEB18-8	FBV985-8	HSV4301	MSV5401	
CF54	VS34 <small>Double</small>	ST55	VSK41P	CA64	CB11	BEB18-8	FBV985-8	HSV4301	MSV5401	
CF41	VS34 <small>Double</small>	ST55	VSK41P	CA64	CB11	BEB18-8	FBV985-8	HSV4301	MSV5401	
CF41	VS34 <small>Double</small>	VRT01	VSK01P	CA64	CB11	BEB18-8	FBV985-8	HSV4301	MSV5401	
CF41	VS34 <small>Double</small>	VRT01	VSK01P	CA64	CB11	BEB18-8	FBV985-8	HSV4301	MSV5401	
CF20	-	-	-	CA30	CB05	BEB18-8	FBV985-6	-	-	AST14 is the cam for your SRI 130 giving an impressive increase of 14 bhp at the top end and 9 bhp in the mid range. S36 Mechanical Adjusters - Straightforward installation - tappet adjustment to be set with cam carrier removed CF20 Cam Followers - to be used with S36 and hydraulic cams S64 Competition Lash Cap - Improved location between retainer and rocker.
CF20	VS37 <small>Single</small>	-	-	CA30	CB05	BEB18-8	FBV985-6	-	-	
CF20	VS37 <small>Single</small>	-	-	CA30	CB05	BEB18-8	FBV985-6	-	-	
CF20	VS37 <small>Single</small>	-	-	CA30	CB05	BEB18-8	FBV985-6	-	-	
CF20	-	S36	VSK43P	CA30	CB05	BEB18-8	FBV985-6	-	-	
CF20	-	S36	VSK43P	CA30	CB05	BEB18-8	FBV985-6	-	-	

PART No.	APPLICATION See page 3 for key to Camshaft descriptions	POWER BAND	CAM LIFT INLET/EXHAUST	VALVE LIFT INLET/EXHAUST	DURATION INLET/EXHAUST	TIMING FIGURES	INLET EXHAUST @ FULL LIFT	V/CLEARANCE INLET/EXHAUST	VALVE LIFT INLET	@ TDC EXHAUST
----------	--	------------	---------------------------	-----------------------------	---------------------------	-------------------	------------------------------	------------------------------	---------------------	------------------

VAUXHALL / OPEL 1.4 1.6 16V CORSA, TIGRA, ASTRA

Durations of hydraulic profiles quoted at .004" / .10mm. Mechanical profiles checked at .010" / .25mm checking height

COR1601 Kit Available	SPORTS INJECTION Hydraulic Suitable for 1.4 10bhp approx increase	2000-6500	.335" 8.50mm	.335" 8.50mm	244°	12/52 52/12	110° 110°	.000" 0.00mm	.007" 0.18mm	.012" 0.30mm
COR1602 Kit Available	SPORTS INJECTION Hydraulic Suitable for 1.6 12bhp approx increase	2000-6500	.372" 9.45mm	.372" 9.45mm	256°	18/58 58/18	110° 110°	.000" 0.00mm	.028" 0.71mm	.028" 0.71mm
COR1612	SPORTS 'R' Hydraulic Modified Injection	2500-7000	.397" 10.08mm	.397" 10.08mm	260°	20/60 60/20	110° 110°	.000" 0.00mm	.048" 1.22mm	.048" 1.22mm
COR1603	COMPETITION Hydraulic	3000-7500	.435" 11.04mm	.435" 11.04mm	278°	31/67 67/31	108° 108°	.000" 0.00mm	.080" 2.03mm	.080" 2.03mm
COR1615	COMPETITION Mechanical	3500-8000	.453" 11.50mm	.443" 11.25mm	296°	42/74 74/42	106° 106°	.010" 0.25mm	.100" 2.54mm	.084" 2.13mm
COR1616	COMPETITION Mechanical	4000-8500	.453" 11.50mm	.443" 11.25mm	300°	46/74 74/46	104° 104°	.010" 0.25mm	.145" 3.68mm	.145" 3.68mm

VAUXHALL / OPEL 1.8 2.0 2.2 16V ECOTEC

Durations of hydraulic profiles quoted at .004" / .10mm. Mechanical profiles checked at .010" / .25mm checking height

EC2001 Kit Available	SPORTS INJECTION Hydraulic 12bhp approx increase	2000-6500	.400" 10.16mm	.400" 10.16mm	256°	18/58 58/18	110° 110°	.000" 0.00mm	.033" 0.84mm	.036" 0.91mm
EC2002	COMPETITION Hydraulic	3000-7500	.435" 11.04mm	.435" 11.04mm	278°	31/67 67/31	108° 108°	.000" 0.00mm	.080" 2.03mm	.080" 2.03mm
EC2005	COMPETITION Mechanical	4000-8000	.444" 11.27mm	.434" 11.02mm	296°	42/74 74/42	106° 106°	.010" 0.25mm	.126" 3.20mm	.122" 3.10mm
EC2006	RACE Mechanical	4500-8500	.472" 11.98mm	.462" 11.73mm	314°	53/87 87/53	104° 104°	.010" 0.25mm	.151" 3.83mm	.146" 3.70mm

VAUXHALL / OPEL 1600/1900/2000 RWD CIH ENGINE

All Cams in this range will fit with no additional machining required but must be checked. Solid Followers must be used throughout this range.

OP214 Kit Available	SPORTS 8bhp approx increase	2000-6500	.293" 7.43mm	.429" 10.89mm	278°	33/65 65/33	107°	.016" 0.41mm	.096" 2.44mm	N/A
OP234	COMPETITION For 2000cc	2000-6000	.293" 7.43mm	.429" 10.89mm	280°	37/63 73/27	103°	.016" 0.41mm	.112" 2.84mm	N/A

There is no substitute for the next three cams. they are all high lift/high torque cams with phenomenal mid range and top end power.

OP244	SPORTS 'R'	2500-7000	.309" 7.84mm	.447" .445" 11.35mm 11.30mm	290°	42/68 78/32	103°	.022" .024" 0.56mm 0.61mm	.138" 3.50mm	N/A
OP254	COMPETITION	3000-7500	.324" 8.22mm	.470" .468" 11.93mm 11.88mm	300°	47/73 83/37	103°	.022" .024" 0.56mm 0.61mm	.169" 4.29mm	N/A
OP264	RACE	4000-8000	.339" 8.60mm	.493" .491" 12.52mm 12.47mm	310°	52/78 88/42	103°	.022" .024" 0.56mm 0.61mm	.190" 4.82mm	N/A

VAUXHALL / OPEL 400 16v DOHC

Direct acting. Durations quoted at .010" / .25mm checking height

OP4001	COMPETITION Phase 1	-	.415" 10.54mm	.407" 10.33mm	282°	35/67 67/35	106°	.008" 0.20mm	.110" 2.79mm	.095" 2.41mm
OP4002	COMPETITION Phase 2	-	.408" .380" 10.36mm 9.65mm	.398" .370" 10.10mm 9.40mm	306° 295°	47/79 73/42	106° 105°	.010" 0.25mm	.130" 3.30mm	.113" 2.87mm
OP4003	COMPETITION Phase 3	-	.431" 10.94mm	.421" 10.69mm	316°	56/80 80/56	102°	.010" 0.25mm	.168" 4.26mm	.163" 4.14mm

CAM FOLLOWER	VALVE SPRING	VALVE SPRING RETAINER	VALVE SPRING KIT	POWER PULLEY	CAM BELT	CONROD BOLT	HEADSTUD KIT	OPTIONAL COMPONENTS
--------------	--------------	-----------------------	------------------	--------------	----------	-------------	--------------	---------------------

CF54	-	-	-	-	CB19	BEB24-8	HSCOR 16V	FBV 826/6 ARP Flywheel Bolts VSK27 Single Valve Spring Kit ST45 Competition Steel Valve Spring Retainer Corsa Power Pulleys (CA74) are suitable for competition use only, where the standard ECU is not used.
CF54	-	-	-	-	CB19	BEB24-8	HSCOR 16V	
CF54	VS55 Single	ST45	VSK27P	-	CB19	BEB24-8	HSCOR 16V	
CF54	VS55 Single	ST45	VSK27P	CA74	CB19	BEB24-8	HSCOR 16V	
CF41	VS34 Double	VRT08	VSK08P	CA74	CB19	BEB24-8	HSCOR 16V	
CF41	VS34 Double	VRT08	VSK08P	CA74	CB19	BEB24-8	HSCOR 16V	

CF54	-	-	-	-	-	-	-	EC2001 will give an improvement of 12 bhp CA71 adjustable Power Pulley. Competition use only. Oil Raiser supplied with cam to be fitted to head drain hole to raise the oil level in the cylinder head VS26 Spring Spacers are to replace rotators on the exhaust valves.
CF54	VS55 Single	VRT21	VSK38P	CA71	-	BEB18-8	-	
CF41	VS34 Double	VRT21	VSK21P	CA71	-	BEB18-8	-	
CF41	VS34 Double	VRT21	VSK21P	CA71	-	BEB18-8	-	

Valve Lifts are quoted using a theoretical Rocker Ratio of 1.52:1 Durations quoted at .016" / .40mm checking height

CF21	VS26 Single	VR7	-	S14	-	-	-
CF21	VS26 Single	VR7	-	S14	-	-	-

All Cams need Kent Special Valve Springs and additional machining may be required.

CF21	VS26 Single	VR7	-	S14	-	-	-
CF21	VS26 Single	VR7	-	S14	-	-	-
CF21	VS26 Single	VR7	-	S14	-	-	-



PART No.	APPLICATION See page 3 for key to Camshaft descriptions	POWER BAND	CAM LIFT INLET/EXHAUST	VALVE LIFT INLET/EXHAUST	DURATION INLET/EXHAUST	TIMING FIGURES	INLET TIMING @ FULL LIFT	V/CLEARANCE INLET/EXHAUST	VALVE LIFT INLET	@ TDC EXHAUST
VW GOLF / SCIROCCO 1600/1800 Mechanical Profiles Pre '86 Direct acting. Durations quoted at .010"/.25mm checking height										
GS1	SPORTS Carburation models. No piston mods	2000-6000	.405" 10.82mm	.393" 9.98mm	280°	30/70 70/30	110°	.012" 0.30mm	.083" 2.10mm	N/A -
GS2 Kit Available	SPORTS INJECTION No piston mods 14bhp approx increase	2000-6500	.431" 10.94mm	.419" .417" 10.64mm 10.59mm	290°	35/75 75/35	110°	.012" .014" 0.30mm 0.35mm	.074" 1.88mm	N/A -
GS25	SPORTS 'R' Carburation and Injection. No piston mods	2250-6750	.426" 10.82mm	.416" 10.56mm	294°	42/72 72/42	105°	.010" 0.25mm	.081" 2.05mm	N/A -
GS3	COMPETITION For best results use twin 40's Valve springs must be checked - minimal clearance	2500-7000	.470" 11.93mm	.458" .456" 11.63mm 11.58mm	300°	48/72 80/40	102°	.012" .014" 0.30mm 0.35mm	.187" 4.75mm	N/A -
GS6	RACE	4000-8500	.480" 12.19mm	.470" .468" 11.93mm 11.88mm	316°	57/79 83/53	101°	.010" .012" 0.25mm 0.30mm	.231" 5.86mm	N/A -

VW GOLF / SCIROCCO 1600/1800 Hydraulic Profiles Post '86 Direct acting. Durations quoted at .004"/.10mm checking height										
GS1H Kit Available	SPORTS INJECTION 10bhp approx increase Carburation and injection. No piston mods. Suitable for catalyst	1500-6000	.440" 11.17mm	.440" 11.17mm	266°	21/65 65/21	112°	.000" 0.00mm	.054" 1.37mm	N/A -
GS2H Kit Available	SPORTS 'R' 14bhp approx increase Carburation and injection. No piston mods.	2000-6500	.446" 11.32mm	.446" 11.32mm	270°	25/65 65/25	110°	.000" 0.00mm	.061" 1.55mm	N/A -
GS3H	COMPETITION Modified injection	2500-7000	.454" 11.53mm	.454" 11.53mm	285°	33/72 72/33	110°	.000" 0.00mm	.078" 1.98mm	N/A -

VW GOLF / CORRADO / BEETLE 2.0 LITRE Hydraulic Profiles Direct acting. Durations quoted at .004"/.10mm checking height										
GS22H Kit Available	SPORTS INJECTION 10bhp approx increase	1500-6000	.440" 11.17mm	.440" 11.17mm	260°	18/62 62/18	112°	.000" 0.00mm	.054" 1.37mm	N/A -
GS23H	SPORTS 'R' Modified injection	2500-7000	.454" 11.53mm	.454" 11.53mm	285°	33/72 72/33	110°	.000" 0.00mm	.078" 1.98mm	N/A -

VW GOLF G60 1.8 Litre Direct acting. Durations quoted at .004"/.10mm checking height										
GS4H Kit Available	SPORTS 14bhp approx increase No piston mods. Suitable for catalyst	1500-6000	.440" 11.17mm	.440" 11.17mm	266°	21/65 65/21	112°	.000" 0.00mm	.054" 1.37mm	N/A -

CAM FOLLOWER	VALVE SPRING	VALVE SPRING RETAINER	VALVE SPRING KIT	POWER PULLEY	CAM BELT	CONROD BOLT	HEADSTUD KIT	OPTIONAL COMPONENTS
-	-	-	-	CA32	CB06	BEB34-8 BEB35-8	HSVW4703	GS3 & GS6 Now have Spring Kits available including: Valve Springs, Titanium Valve Spring Retainers and Platforms.
-	-	-	-	CA32	CB06	BEB34-8 BEB35-8	HSVW4703	
-	-	-	-	CA32	CB06	BEB34-8 BEB35-8	HSVW4703	
CF71	VS39 Double	VRT22	VSK22P	CA32	CB06	BEB34-8 BEB35-8	HSVW4703	
CF71	VS39 Double	VRT22	VSK22P	CA32	CB06	BEB34-8 BEB35-8	HSVW4703	CF71 Uses shim underneath for ultimate reliability
								BEB34-8 VW Late 8mm Type Conrod Bolt
								BEB35-8 VW Early 9mm Type Conrod Bolt

CF38	-	-	-	CA32	CB06	BEB34-8 BEB35-8	HSVW4703	GS2H was tested by VW Magazine and found to be the best all round. It gave 14bhp over the original and idle was no problem. The test car owner had the GS2H refitted at the end of the test day because of the characteristics.
CF38	-	-	-	CA32	CB06	BEB34-8 BEB35-8	HSVW4703	
CF38	-	-	-	CA32	CB06	BEB34-8 BEB35-8	HSVW4703	
CF38	-	-	-	CA32	CB25	-	HSVW4703	BEB34-8 VW Late 8mm Type Conrod Bolt
CF38	-	-	-	CA32	CB25	-	HSVW4703	BEB35-8 VW Early 9mm Type Conrod Bolt
								GS4H Was tested by the Golf Magazine and found 14bhp increase.
CF38	-	-	-	CA32	CB06	-	HSVW4703	

PART No.	APPLICATION See page 3 for key to Camshaft descriptions	POWER BAND	CAM LIFT INLET/EXHAUST	VALVE LIFT INLET/EXHAUST	DURATION INLET/EXHAUST	TIMING FIGURES	INLET EXHAUST @ FULL LIFT	V/CLEARANCE INLET/EXHAUST	VALVE LIFT INLET	@ TDC EXHAUST
----------	--	------------	---------------------------	-----------------------------	---------------------------	-------------------	------------------------------	------------------------------	---------------------	------------------

VW GOLF VR6 Duration of hydraulic profiles quoted at .004"/.10mm.

VR602	SPORTS INJECTION	2000-6500	.431" 10.94mm	.431" 10.94mm	264°	22/62 62/22	110°	.000" 0.00mm	.065" 1.65mm	N/A
-------	------------------	-----------	------------------	------------------	------	-------------	------	-----------------	-----------------	-----

VW GOLF 16 Valve 1800 / 2000 Duration of hydraulic profiles quoted at .004"/.10mm. Mechanical profiles checked at .010"/.25mm checking height

GF1602R <small>Kit Available</small>	SPORTS INJECTION <small>Hydraulic 17bhp approx increase</small>	2000-6500	.431" .404" 10.94mm 10.26mm	.431" .404" 10.94mm 10.26mm	264° 258°	22/62 59/19	110° 110°	.000" 0.00mm	.055" 1.40mm	.055" 1.40mm
GF1603	SPORTS 'R' <small>Hydraulic</small>	3000-7500	.435" 11.04mm	.435" 11.04mm	278°	31/67 67/31	108° 108°	.000" 0.00mm	.080" 2.03mm	.080" 2.03mm
GF1604	COMPETITION <small>Hydraulic</small>	3500-8000	.445" 11.30mm	.445" 11.30mm	296°	42/74 74/42	106° 106°	.000" 0.00mm	.124" 3.15mm	.117" 2.97mm
GF1605	COMPETITION <small>Mechanical</small>	4000-8000	.455" 11.55mm	.445" 11.30mm	304°	46/78 78/46	106° 106°	.010" 0.25mm	.120" 3.05mm	.112" 2.84mm
GF1606	RACE <small>Mechanical</small>	4500-8500	.472" 11.98mm	.462" 11.73mm	314°	53/81 81/53	104° 104°	.010" 0.25mm	.151" 3.83mm	.146" 3.70mm

VW GOLF 1.8 D.O.H.C. 5 Valve GTi Duration of Hydraulic profiles quoted at .004"/.10mm. Mechanical profiles checked at .010"/.25mm checking height

GF5V1	SPORTS <small>Hydraulic</small>	1000-6000	.358" .409" 9.10mm 10.40mm	.358" .409" 9.10mm 10.40mm	268° 260°	22/66 64/16	112° 114°	.000" .000" 0.00mm 0.00mm	.040" 1.01mm	.022" 0.55mm
GF5V2	SPORTS 'R' <small>Hydraulic - Modified Injection/Carburettors</small>	2500-7000	.380" .445" 9.65mm 11.30mm	.380" .445" 9.65mm 11.30mm	293° 295°	38/75 76/39	108° 108°	.000" 0.00mm	.108" 2.74mm	.108" 2.74mm
GF5V4	COMPETITION <small>Mechanical</small>	3000-7500	.384" .444" 9.75mm 11.27mm	.374" .434" 9.50mm 11.02mm	308° 297°	48/80 75/42	106° 106°	.010" .010" 0.25mm 0.25mm	.106" 2.69mm	.122" 3.10mm

VW GOLF 1.8T D.O.H.C. 5 Valve GTi TURBO Duration of Hydraulic profiles quoted at .004"/.10mm. Mechanical profiles checked at .010"/.25mm checking height

GF5VT3	SPORTS <small>Hydraulic</small>	1000-6000	.341" .401" 8.68mm 10.21mm	.341" .401" 8.68mm 10.21mm	250°	11/59 59/11	114° 114°	.000" .000" 0.00mm 0.00mm	.015" 0.38mm	.014" 0.35mm
--------	------------------------------------	-----------	-------------------------------	-------------------------------	------	-------------	-----------	------------------------------	-----------------	-----------------

CAM FOLLOWER	VALVE SPRING	VALVE SPRING RETAINER	VALVE SPRING KIT	ALLOY POWER PULLEY	CAM BELT	HEAD STUD KIT	CONROD BOLT	OPTIONAL COMPONENTS
--------------	--------------	-----------------------	------------------	--------------------	----------	---------------	-------------	---------------------

CF67	-	-	-	-	-	HSVW4705	BEB39-12	
------	---	---	---	---	---	----------	----------	--

CF62	-	-	-	CA68 S69	CB23 CB24	HSVW4702	BEB34-8	
CF62	VS34 <small>Double</small>	VRT14 VRT27	VSK14P VSK37P	CA68 S69	CB23 CB24	HSVW4702	BEB34-8	
CF62	VS34 <small>Double</small>	VRT14 VRT27	VSK14P VSK37P	CA68 S69	CB23 CB24	HSVW4702	BEB34-8	
CF42	VS34 <small>Double</small>	VRT14 VRT27	VSK14P VSK37P	CA68 S69	CB23 CB24	HSVW4702	BEB34-8	
CF42	VS34 <small>Double</small>	VRT14 VRT27	VSK14P VSK37P	CA68 S69	CB23 CB24	HSVW4702	BEB34-8	

-	-	-	-	-	CB29	-	-	
-	-	-	-	-	CB29	-	-	
-	-	-	-	-	CB29	-	-	

-	-	-	-	-	CB29	-	-	
---	---	---	---	---	------	---	---	--

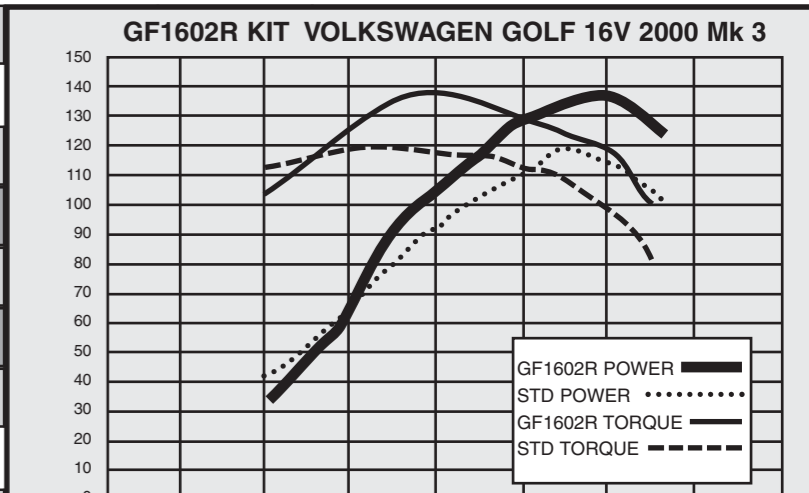

- BHP**
- RPM**
- VRT14 Titanium Retainer for Triple Groove Valve
 - VRT27 Titanium Retainer for Single Groove Valve
 - CA68 Golf/Scirocco/Corrado 1800-2000 16V Power Pulley for Belt Drive
 - S69 Golf/Scirocco/Corrado 1800-2000 16V Power Pulley for Gear Drive
 - CB23 Golf/Scirocco/Corrado 2.0 16V Cam Belt
 - CB24 Golf/Scirocco/Corrado 1.8 16V Cam Belt
 - VSK14P Suitable for 1.8/2.0 16V Triple Groove Type Valve
 - VSK37P Suitable for 1.8/2.0 16V Single Groove Type Valve

CLUB MOTORSPORT CONTROL CAMSHAFTS

PART NO	APPLICATION	CAM LIFT INLET / EXHAUST	VALVE LIFT INLET / EXHAUST	DURATION INLET / EXHAUST	FULL LIFT POSITION INLET / EXHAUST	V/CLEARANCE INLET / EXHAUST
NATIONAL AUTOGRASS SPORT ASSOCIATION						
NASA199	CLASS 1	Specification as per NASA regulation book				
NOVA 1.3	CLASS 2	Specification as per NASA regulation book				
MINICROSS DRIVERS ASSOCIATION						
MDA	JUNIOR MINICROSS	6.78mm	8.28mm	250 262	107.5	0.4mm
FORMULA FORD 1600						
FORD1.6 X-FLOW	FORMULA FORD	5.86mm 5.89mm	8.66mm 8.55mm	272 272	109	0.25mm 0.55mm
SPEDEWORTH						
FORD 2.0 PINTO	STOCK CAR	7.3mm	12.08mm 11.79mm	312	-	0.25mm 0.25mm
750 MOTOR CLUB						
CITREON SAXO VTR						
KC750R	STOCK HATCH	5.29mm 5.28mm	9.06mm 8.84mm	277 282	-	0.2mm 0.4mm
CITREON SAXO VTR -PEUGEOT 106 XSI RALLYE						
KC750J	STOCK HATCH	6.67mm 6.66mm	9.14mm 8.92mm	269 290	-	0.2mm 0.4mm
KC750N	STOCK HATCH	6.67mm 6.66mm	9.14mm 8.92mm	269 290	-	0.2mm 0.4mm
PEUGEOT 205 GTI						
KC750205	STOCK HATCH	11.2mm 10.4mm	11.05mm 10.15mm	290 278	-	0.15mm 0.25mm
FORD XR2 XR3						
KC7501614767	STOCK HATCH	6.0mm 6.0mm	9.9mm 9.9mm	262 270	-	0.00mm
FORD XR2I XR3I						
KC7506186554	STOCK HATCH	6.04mm 6.04mm	9.98mm 9.98mm	266 270	-	0.00mm
VAUXHALL 1.6 8V GTE GSI						
KC750SE	STOCK HATCH	5.98mm	10.1mm	262 262	-	0.00mm
FORD ZETEC 16V						
KC75061234	KIT CAR - Formula 4	9.31/9.41mm inlet 8.61/8.7mm exhaust	9.31/9.41mm inlet 8.61/8.7mm exhaust	260/272 260/267	-	0.00mm 0.00mm
FORD ZETEC 16V						
KC750FZ134	KIT CAR	11.04mm	11.04mm	278	108 106	0.00mm
FORD DURATEC 16V						
KC750DUR145	KIT CAR	9.08mm 8.04mm	8.83mm 7.79mm	257 252	110 106	0.25mm 0.25mm
FORD X-FLOW						
KC750 P103-4	LOWCOST SERIES	5.86mm 5.89mm	8.66mm 8.55mm	272 272	109	0.25mm 0.55mm

HONDA

Part No	Application	Cam Lift Inlet	Cam Lift Exhaust	Duration at 1mm Inlet	Duration at 1mm Exhaust	lobe centre angle Inlet	lobe centre angle Exhaust	Valve Clearance Inlet	Valve Clearance Exhaust	Valve Lift at TDC Inlet	Valve Lift at TDC Exhaust
SUPERSPORT											
HON 33	CBR600RR7 SUPERSPORT	8.50mm	7.40mm	256	242	106	108	0.20mm	0.25mm	2.74mm	1.58mm
HON 30	CBR600RR3 SUPERSPORT	8.50mm	7.40mm	260	242	105	105	0.20mm	0.25mm	2.94mm	1.80mm
HON 25	CBR600RR3 SUPERSPORT	8.50mm	7.40mm	252	240	106	108	0.20mm	0.25mm	2.87mm	1.51mm
HON 20	CBR600FSX 1999 SUPERSPORT	8.63mm	7.41mm	252	240	104	104	0.20mm	0.25mm	2.80mm	1.93mm
HON 11	CBR600 POST FM SUPERSPORT	8.18mm	7.39mm	242	240	103	104	0.15mm	0.20mm	2.52mm	2.00mm
HON 12	CBR600 POST FM SUPERSPORT	8.25mm	7.41mm	250	240	104	104	0.15mm	0.20mm	2.87mm	2.00mm
HON 14	CBR600 POST FM RACE	8.99mm	8.22mm	247	242	104	103	0.15mm	0.20mm	2.88mm	2.30mm
SUPERBIKE											
HON 41	CBR1000RR11 RACE NEW	10.15mm	9.30mm	262	258	109	108	0.20mm	0.30mm	3.06mm	2.48mm
HON 40	CBR1000RR8 RACE	10.20mm	8.95mm	262	255	105	110	0.20mm	0.30mm	3.20mm	2.40mm
HON 36	CBR1000RR8 RACE	9.44mm	8.66mm	256	256	106	109	0.20mm	0.30mm	2.80mm	2.20mm
HON 34	CBR1000RR6 RACE	9.66mm	9.27mm	264	262	107	105	0.20mm	0.30mm	3.22mm	2.85mm
HON 29	CBR1000RR4 RACE	9.06mm	8.74mm	258	258	105	105	0.20mm	0.20mm	2.90mm	2.70mm
HON 28	CBR1000RR4 RACE	9.14mm	8.60mm	252	246	105	107	0.20mm	0.20mm	2.64mm	2.19mm
OFF ROAD											
HON 37	CRF150 2007 MOTOCROSS	8.46mm		250		105		0.20mm		2.65mm	
HON 38	CRF250 2007 MOTOCROSS	9.00mm		248		110		0.20mm		2.10mm	
HON 31	CRF250 SUPERMOTO	8.70mm		252		105		0.20mm		2.67mm	
HON 39	CRF450 2007 MOTOCROSS	10.25mm		262		108		0.20mm		2.90mm	
HON 32	CRF450 SUPERMOTO	10.25mm		260		105		0.20mm		3.25mm	
STREET COMPETITION											
HON 4	XBR500 STREET	6.50mm	6.50mm	249	249	109		0.13mm	0.18mm		
HON 5	XBR500 RACE	7.41mm	7.41mm	260	260	107		0.13mm	0.18mm		
HON 15	CBR900 FIREBLADE STREET	8.30mm	8.17mm	250	242	104	104	0.15mm	0.20mm	2.87mm	2.20mm
HON 26	CBR900RR2 RACE 954CC	9.04mm	8.81mm	248	251	105	108	0.20mm	0.25mm	2.49mm	2.00mm
HON 22	CBR900 RRY injection model	9.14mm	8.94mm	254	248	102	104	0.15mm	0.20mm	3.25mm	2.53mm
HON 21	VTR10000 SP1 RACE	11.12mm	11.12mm	263	263	106	104	0.20mm	0.30mm	3.73mm	3.22mm
HON 18	CBR1100 BLACKBIRD RACE	9.27mm	8.58mm	248	242	104	104	0.15mm	0.20mm	2.76mm	2.20mm

KAWASAKI

Part No	Application	Cam Lift Inlet	Cam Lift Exhaust	Duration at 1mm Inlet	Duration at 1mm Exhaust	lobe centre angle Inlet	lobe centre angle Exhaust	Valve Clearance Inlet	Valve Clearance Exhaust	Valve Lift at TDC Inlet	Valve Lift at TDC Exhaust
SUPERSPORT											
KAW 33	ZX6RR 2009 SUPERSPORT	8.55mm	7.17mm	252	230	107	110	0.15mm	0.20mm	2.40mm	1.15mm
KAW 29	ZX6RR 2008 SUPERSPORT	8.30mm	7.45mm	246	234	105	106	0.20mm	0.25mm	2.30mm	1.55mm
KAW 24	ZX6RR 2003 SUPERSPORT	8.15mm	7.16mm	250	232	105	105	0.20mm	0.20mm	2.35mm	1.52mm
KAW 21	ZX6R SUPERSPORT	9.19mm	8.45mm	252	246	103	106	0.20mm	0.20mm	2.83mm	2.25mm
KAW 11	ZX6R SUPERSPORT	9.19mm	8.45mm	255	249	102	105	0.20mm	0.20mm	2.91mm	2.34mm
KAW 12	ZX6R RACE	9.75mm	8.45mm	249	249	102	105	0.20mm	0.20mm	3.15mm	2.34mm
KAW 2	ZZR600 RACE	8.99mm	8.43mm	255	237	105	105	0.15mm	0.15mm	2.88mm	2.88mm
SUPERBIKE											
KAW 35	ZX10R 20011 RACE NEW	11.20mm	9.40mm	262	258	110	110	0.20mm	0.20mm	2.95mm	2.40mm
KAW 30	ZX10R 2008 RACE	9.70mm	8.46mm	260	250	105	105	0.20mm	0.20mm	3.15mm	2.55mm
KAW 32	ZX10R 2008 RACE	10.2mm	8.80mm	262	254	105	108	0.20mm	0.20mm	3.20mm	2.65mm
KAW 25	ZX10-R 2005 RACE	8.94mm	8.67mm	254	250	105	105	0.20mm	0.20mm	2.83mm	2.30mm
KAW 27	ZX10-R 2005 RACE	9.70mm	8.70mm	260	252	104	106	0.20mm	0.20mm	3.27mm	2.44mm
OFF ROAD											
KAW 26	KX250F SUPERMOTO	9.04mm	8.22mm	248	242	103	104	0.20mm	0.20mm	2.96mm	2.20mm
KAW 31	KZ250F 2009	9.15mm	8.55mm	248	242	103	104	0.20mm	0.20mm	2.80mm	2.10mm
STREET COMPETITION											
KAW 15	ZXR400 RACE	5.76mm	5.35mm	244	244	105	105	0.15mm	0.20mm		
KAW 34	ER6 RACE	9.00mm	8.40mm	240	236	105	107	0.20mm	0.25mm	2.10mm	1.45mm
KAW 18	ZX7RR RACE	9.55mm	8.58mm	250	242	105	105	0.20mm	0.25mm	2.82mm	2.06mm
KAW 20	ZX9R RACE C MODEL	9.75mm	8.96mm	250	238	105	105	0.20mm	0.25mm	2.84mm	1.90mm
KAW 22	ZX9RF RACE	9.75mm	9.04mm	250	248	105	105	0.20mm	0.25mm	2.84mm	2.15mm
KAW 8	GPZ900 STREET	6.65mm	6.65mm	244	244	104	104	0.15mm	0.20mm		
KAW 10	Z900 STREET 1973-1982	8.99mm	8.99mm	255	255	110	110	0.13mm	0.18mm	2.40mm	2.40mm
KAW 16	Z900 COMPETITION 1973-1982	9.88mm	9.88mm	260	260	110	110	0.15mm	0.20mm	2.65mm	2.60mm
KAW 17	Z900 RACE 1973-1982	10.56mm	10.56mm	266	266	110	110	0.15mm	0.20mm	3.00mm	2.90mm
KAW 4	ZZR1100 RACE	7.29mm	7.11mm	260	243	105	105	0.15mm	0.20mm		
KAW 23	ZX12R RACE	10.08mm	9.62mm	260	258	108	108	0.20mm	0.25mm	3.07mm	2.70mm
KAW 28	ZX12R STREET	9.70mm	9.15mm	260	254	108	108	0.20mm	0.25mm	2.85mm	2.15mm

SUZUKI

Part No	Application	Cam Lift Inlet	Cam Lift Exhaust	Duration at 1mm Inlet	Duration at 1mm Exhaust	lobe centre angle Inlet	lobe centre angle Exhaust	Valve Clearance Inlet	Valve Clearance Exhaust	Valve Lift at TDC Inlet	Valve Lift at TDC Exhaust
SUPERSPORT											
SUZ 48	GSXR600K11 SUPERSPORT	7.80mm	7.80mm	240	240	108	110	0.2mm	0.2mm	1.80mm	1.60mm
SUZ 44	GSXR600K8 SUPERSPORT	8.18mm	8.00mm	264	240	102	108	0.2mm	0.2mm	3.15mm	1.70mm
SUZ 41	GSXR600K6 SUPERSPORT	8.50mm	8.00mm	252	232	105	107	0.20mm	0.20mm	2.70mm	1.57mm
SUZ 33	GSXR600K4 SUPERSPORT	8.50mm	7.23mm	262	250	105	110	0.20mm	0.20mm	3.05mm	1.87mm
SUZ 34	GSXR600K4 SUPERSPORT	8.50mm	7.23mm	262	238	105	105	0.20mm	0.20mm	3.05mm	1.87mm
SUZ 26	GSXR600K1 SUPERSPORT	8.50mm	7.23mm	252	237	105	105	0.20mm	0.20mm	2.69mm	1.66mm
SUZ 27	GSXR600K1 SUPERSPORT	8.50mm	7.23mm	252	250	105	112	0.20mm	0.20mm	2.69mm	1.71mm
SUPERBIKE											
SUZ 45	GSXR1000K8 RACE	9.70mm	8.95mm	260	254	103	105	0.20mm	0.25mm	3.35mm	2.90mm
SUZ 40	GSXR1000K5 RACE	10.18mm	8.81mm	261	256	105	105	0.20mm	0.20mm	3.20mm	2.78mm
SUZ 37	GSXR1000K5 RACE	10.18mm	8.60mm	260	244	105	105	0.20mm	0.20mm	3.20mm	2.10mm
SUZ 31	GSXR1000K3 RACE	10.23mm	8.45mm	258	236	105	105	0.25mm	0.25mm	3.20mm	1.61mm
SUZ 29	GSXR1000K1 RACE	9.60mm	8.60mm	258	243	105	105	0.25mm	0.25mm	3.20mm	2.07mm
SUZ 28	GSXR1000K1 RACE	9.72mm	8.43mm	254	236	105	105	0.25mm	0.25mm	2.85mm	1.63mm
OFF ROAD											
SUZ 46	RMZ250 2007 - 2009	9.39mm	8.97mm	248	254	105	102	0.20mm	0.20mm	2.45mm	2.95mm
SUZ 36	RMZ250 2004 - 2006	9.04mm	8.22mm	248	242	103	104	0.20mm	0.20mm	2.96mm	2.20mm
SUZ 47	RMZ450 2007 - 2009	9.85mm	9.64mm	252	254	108	108	0.20mm	0.20mm	2.55mm	2.50mm
SUZ 39	RMZ450 2005 - 2006	9.70mm	8.48mm	252	258	105	105	0.20mm	0.20mm	2.90mm	2.77mm
TRACK CAR											
SUZ 24	GSXR1300 HAYABUSA RACE	9.27mm	8.15mm	248	234	105	105	0.20mm	0.20mm	2.60mm	1.66mm
SUZ 38	GSXR1300 HAYABUSA RACE	9.70mm	9.00mm	260	248	105	105	0.20mm	0.20mm	3.16mm	2.43mm
STREET COMPETITION											
SUZ 18	GSF600 BANDIT STREET	5.84mm	5.84mm	244	244	110	110	0.15mm	0.15mm		
SUZ 43	SV 650 INJECTION RACE	9.30mm	8.00mm	246	234	105	106	0.20mm	0.25mm	2.60mm	1.40mm
SUZ 22	SV650-CARB RACE	8.43mm	6.73mm	236	214	108	106	0.20mm	0.20mm	1.73mm	0.95mm
SUZ 10	DR650 ENDRUO	6.98mm	6.73mm	244	244	110		0.10mm	0.10mm		
SUZ 42	GSXR750KI-K7 RACE	9.72mm	8.43mm	254	236	105	105	0.25mm	0.25mm	2.85mm	1.63mm
SUZ 4	GS750-GS1000 STREET	8.99mm	8.99mm	255	255	110	110	0.13mm	0.18mm	2.40mm	2.40mm

Part No	Application	Cam Lift Inlet	Cam Lift Exhaust	Duration at 1mm Inlet	Duration at 1mm Exhaust	lobe centre angle Inlet	lobe centre angle Exhaust	Valve Clearance Inlet	Valve Clearance Exhaust	Valve Lift at TDC Inlet	Valve Lift at TDC Exhaust
STREET COMPETITION											
SUZ 16	GS750-GS1000 RACE	9.88mm	9.88mm	260	260	110	110	0.15mm	0.20mm	2.65mm	2.60mm
SUZ 5	GSX750-1000 STREET	5.54mm	5.54mm	249	249	108	108	0.15mm	0.18mm		
SUZ 17	GSX750-GSX1100 RACE	6.02mm	6.02mm	256	256	108	108	0.15mm	0.18mm		
SUZ 6	GSXR750 STREET	5.84mm	5.84mm	244	244	110	110	0.15mm	0.15mm		
SUZ 1	GSXR750-GSXR1100 RACE	6.50mm	6.50mm	249	249	109	109	0.15mm	0.15mm		
SUZ 7	GSXR1100 STREET	6.10mm	6.10mm	245	245	110	110	0.15mm	0.15mm		
SUZ 19	TL 1000R STREET	11.00mm	9.75mm	257	250	110	110	0.20mm	0.20mm	2.88mm	2.23mm
SUZ 20	TL 1000S STREET	10.36mm	9.75mm	256	250	110	110	0.20mm	0.20mm	2.68mm	2.23mm
SUZ 21	TL 1000R/TL1000S RACE	11.00mm	10.18mm	257	258	108	108	0.20mm	0.20mm	3.13mm	2.75mm
SUZ 25	GSXR1100 WP RACE	9.75mm	9.75mm	250	250	108	108	0.20mm	0.25mm	2.53mm	2.40mm
SUZ 12	GSF1200 BANDIT STREET	6.10mm	6.10mm	245	245	110	110	0.15mm	0.15mm		
SUZ 30	GSXR1400 STREET	7.77mm	6.75mm	237	236	105	105	0.20mm	0.20mm	2.10mm	1.77mm

YAMAHA

Part No	Application	Cam Lift Inlet	Cam Lift Exhaust	Duration at 1mm Inlet	Duration at 1mm Exhaust	lobe centre angle Inlet	lobe centre angle Exhaust	Valve Clearance Inlet	Valve Clearance Exhaust	Valve Lift at TDC Inlet	Valve Lift at TDC Exhaust
SUPERSPORT											
YAM 28	YZF R6 2007 SUPERSPORT	8.80mm	8.00mm	260	248	110	110	0.20mm	0.30mm	2.40mm	1.73mm
YAM 26	YZF R6 2006 SUPERSPORT	8.82mm	8.00mm	256	238	105	110	0.20mm	0.30mm	2.55mm	1.37mm
YAM 18	YZF R6 2003 SUPERSPORT	8.40mm	7.50mm	262	246	105	110	0.20mm	0.20mm	3.15mm	1.76mm
YAM 21	YZF R6 2003 SUPERSPORT	8.40mm	7.50mm	256	246	105	108	0.20mm	0.20mm	2.83mm	1.93mm
YAM 14	YZF R6 SUPERSPORT	8.12mm	7.59mm	250	242	104	104	0.20mm	0.25mm	2.63mm	2.05mm
YAM 15	YZF R6 SUPERSPORT	8.12mm	7.59mm	260	250	103	112	0.20mm	0.20mm	3.20mm	1.74mm
YAM 2	FZR 600 SUPERSPORT	7.80mm	7.54mm	307	297	105	105	0.20mm	0.25mm	2.10mm	2.00mm
YAM 8	FZR600 RACE	8.23mm	7.59mm	324	299	104	105	0.20mm	0.25mm	2.82mm	2.00mm

YAMAHA

continued

Part No	Application	Cam Lift Inlet	Cam Lift Exhaust	Duration at 1mm Inlet	Duration at 1mm Exhaust	lobe centre angle Inlet	lobe centre angle Exhaust	Valve Clearance Inlet	Valve Clearance Exhaust	Valve Lift at TDC Inlet	Valve Lift at TDC Exhaust
SUPERBIKE											
YAM 31	R1 2009 RACE	10.20mm	8.80mm	262	254	112	106	0.20mm	0.30mm	2.50mm	2.65mm
YAM 32	R1 2009 RACE	10.40mm	9.10mm	262	254	112	106	0.20mm	0.30mm	2.75mm	2.65mm
YAM 27	R1 2007 RACE	10.35mm	8.99mm	260	254	108	105	0.20mm	0.20mm	3.15mm	2.50mm
YAM 29	R1 2007 RACE	9.50mm	8.60mm	260	254	105	107	0.20mm	0.20mm	2.80mm	2.30mm
YAM 24	R1-2004 RACE	8.70mm	8.45mm	262	254	105	105	0.20mm	0.20mm	3.20mm	2.72mm
YAM 22	R1-2004 RACE	8.83mm	8.45mm	256	256	105	105	0.20mm	0.20mm	2.70mm	2.65mm
YAM 19	YZF R1 RACE	9.47mm	8.63mm	267	250	104	104	0.20mm	0.25mm	3.15mm	2.75mm
YAM 11	YZF R1 RACE	8.07mm	8.63mm	252	252	104	104	0.20mm	0.25mm	2.58mm	2.75mm
YAM 17	YZF R1 RACE	7.64mm	8.12mm	242	249	104	104	0.20mm	0.25mm	2.30mm	2.50mm
OFF ROAD											
YAM 33	YZF250	8.80mm	8.35mm	255	254	106	104	0.15mm	0.20mm	2.65mm	2.60mm
YAM 20	YZF 250	8.48mm	8.48mm	250	250	105	105	0.15mm	0.15mm	2.57mm	2.40mm
YAM 34	YZF450	9.10mm	8.25mm	255	246	108	103	0.15mm	0.20mm	2.70mm	2.60mm
YAM 35	YZF450	9.00mm	8.50mm	268	266	108	103	0.15mm	0.20mm	3.30mm	3.35mm
STREET COMPETITION											
YAM 1	FZR 400 RACE	7.80mm	7.54mm	239	239	105	105	0.20mm	0.25mm	2.10mm	2.00mm
YAM 5	SRX6 600 RACE	7.97mm	7.97mm	259	259	108		0.13mm	0.18mm		
YAM 6	XT 600 ENDURO	7.34mm	7.34mm	259	259	109		0.13mm	0.18mm		
YAM 12	XTZ660 5 VALVE RACE	7.18mm	7.18mm	262	262	108		0.13mm	0.18mm		
YAM 4	FZR 1000 RACE	8.48mm	8.48mm	259	259	105	105	0.13mm	0.15mm	2.57mm	2.40mm
YAM 9	TDM850 ENDURO	8.43mm	8.43mm	240	240	105	109	0.15mm	0.15mm	2.05mm	1.65mm
YAM 7	FJ1200 STREET	8.43mm	8.43mm	237	237	105	105	0.15mm	0.20mm	2.05mm	2.00mm

SLOTTED CAM SPROCKET KITS

MODEL	BORE SIZE	PART NO.	
HONDA			
CRF250		CS22	
CBR600RM-FX-RR		CS01	
CBR600FS		CS02	
CBR900RR		CS03	
CBR900RRY		CS04	
CBR1000RR8		CS06	
CBR1100XXX		CS05	
KAWASAKI			
ZXR400	INC BOSS	CS20	
SUZUKI			
GSXR600 UP TO 2000	INC BOSS	25MM	CS40
GSXR600 K1 2001 - K11	INC BOSS	24MM	CS41
GSXR750WT UP TO 2000	INC BOSS	25MM	CS42
GSXR750 K1 - K7	INC BOSS	24MM	CS43
GSXR1000 K1 - K11	INC BOSS	24MM	CS43
GSXR1300	INC BOSS	25MM	CS44
YAMAHA			
R6 UP TO 2002		CS60	
R6 2006 ON		CS62	
R1 UP TO 2003		CS61	
MOTORCYCLE OVER SIZE SHIMS			
S78	7.5MM X 4.5MM		
S80	9.5MM X 4.8MM		
MOTORCYCLE SHIMS CAN BE GROUND TO SIZE ON REQUEST.			

PERFORMANCE MOTORCYCLE CAMSHAFTS

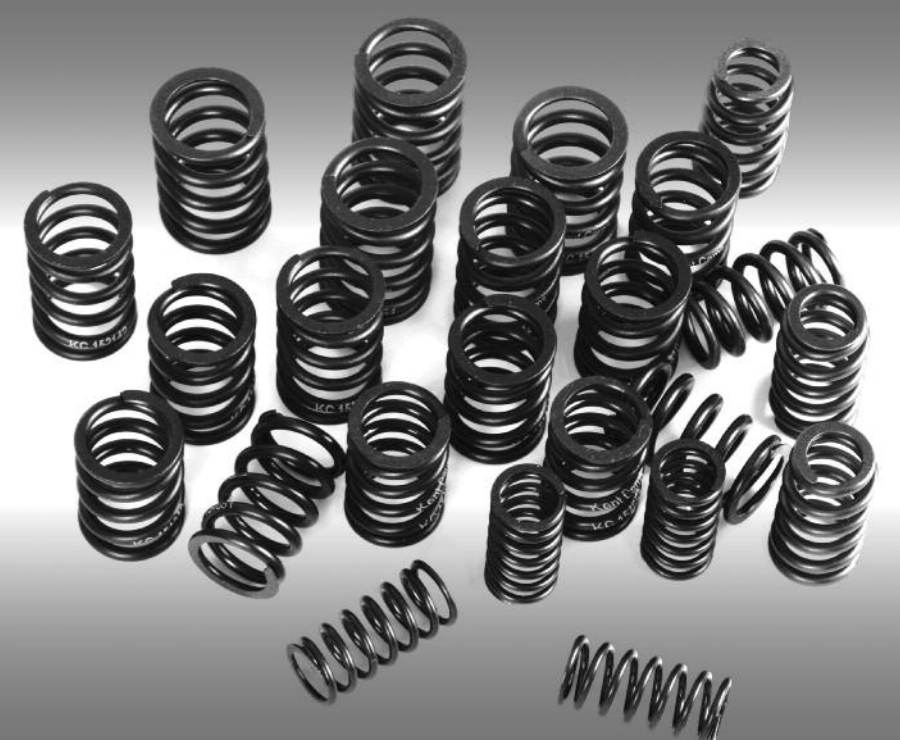

PERFORMANCE COMPONENTS

POWER PULLEYS

	PART No.	PART No.
AUDI	ALLOY	STEEL
80 4 CYL	CA32	
BMW		
6 CYL SMALL BLOCK SERIES	CA39	
CITROEN		
CITROEN AX/SAXO 1.3/1.4/1.6 8V	CA31	
CITROEN SAXO VTS 16V 1.6	CA72	
FIAT		
SOHC 1.4 1.6 UNO, TIPO, PUNTO	CA77	
SOHC 1.1 1.3 UNO	CA40	
TWIN CAM 8V 1.6 / 1.8 / 2.0 (Per pair)	CA41	
TWIN CAM 16V 2.0 (Per pair)	CA83	
FORD		
1600 / 2000 OHC PINTO	CA11	S11
X/FLOW SIMPLEX CAM SPROCKET (Not suitable Fiesta)		S27
X/FLOW DUPLEX KIT (Not suitable Fiesta)		S13
COSWORTH 16V SIERRA (Per pair)	CA28	
ESCORT CVH	CA18	S18
RS2000 16V (Per pair)		S65
ZETEC 16V 1.6 1.8 2.0 (Per pair)	CA59	
ZETEC 'S' 16V 1.25 1.4 1.6 (Per pair)	CA96	
BDA - BDG (Per pair)	CA84	
HONDA		
VTEC (Per pair)	CA70	
K20A Exhaust Gear		S85

	PART No.	PART No.
LOTUS	ALLOY	STEEL
LOTUS TWIN CAM 8 VALVE (Per pair)		S45
LOTUS ELISE 16 VALVE (Per pair)	CA67	
LOTUS 2.2 907 16V (Per pair) Square Tooth	CA80	
LOTUS 2.2 912 16V (Per pair) Round Tooth	CA93	
PEUGEOT		
106/205/206/306 1.3/1.4/1.6 8V (42 Tooth)	CA31	
205/306/309/405 1.6/1.9/2.0 8V (42 Tooth)	CA31	
405 16V / 306 S16 16V (Per pair)	CA42	
106 16V (Per pair)	CA72	
306 GTi 6 1997 on + 406 COUPE (Per pair)	CA78	
RENAULT		
CLIO 16 VALVE (Per pair)	CA65	
ROVER		
A SERIES DUPLEX KIT (Roll chain)		S12
B SERIES DUPLEX KIT (Roll chain)		S19
ROVER V8 DUPLEX KIT ROLL CHAIN		S29
K SERIES 16VMGF 1.8 non VVC (Per pair)	CA67	
SUZUKI	ALLOY	STEEL
1.6 SWIFT 16V (Per pair)	CA81	

	PART No.	PART No.
TOYOTA		
1200/1300		S63
1.6 16V 4AGE (Per pair)	CA79	
TRIUMPH		
DOLOMITE SPRINT		S43
6 CYL CAM SPROCKET		S44
4 CYL 1300 DUPLEX (Crank pulley I.D. 1.000") KIT		S72
4 CYL 1300/1500 DUPLEX (Crank pulley I.D. 1.375") KIT		S73
TR2, 3, 4 DUPLEX KIT		S74
6 CYL DUPLEX KIT		S75
VAUXHALL/OPEL		
MANTA/CAVALIER RWD 1600/1900/2000 CIH HEAD		S14
HS CHEVETTE 16V PER PAIR	CA95	
ASTRA/NOVA 1300	CA23	
ASTRA/CAVALIER/CALIBRA 1600/1800/2000 8 VALVE	CA30	
ASTRA/CAVALIER/CALIBRA 1600/1800/2000 8 VALVE	CA82	(Post 93)
NOVA 1.6 GTE/CORSA 1.4/1.6 8 VALVE	CA55	
ASTRA/CALIBRA/CAVALIER 2.0 16 VALVE	CA64	(Per pair)
ASTRA/CALIBRA/CAVALIER 2.0 16V Low noise type belt	CA66	(Per pair)
VECTRA/ASTRA 1.8/2.0/2.2 16V ECOTEC Competition use only	CA71	(Per pair)
CORSA/TIGRA/ASTRA 1.4/1.6 16V Competition use only	CA74	(Per pair)
VW		
GOLF/CORRADO 1600/1800	CA32	
GOLF/CORRADO 1800/2000 16V POWER PULLEY FOR BELT DRIVE	CA68	
GOLF/CORRADO 1800/2000 16V POWER PULLEY FOR GEAR DRIVE (Pair)		S69
POLO G40	CA97	

POWER PULLEYS



COMPETITION CAM BELTS

	PART No.
CITROEN SAXO VTS 1.6 16V	CB16
FIAT UNO TURBO/PUNTO GT	CB12
FORD ESCORT/ORION 1.3 1980-92	CB01
FORD ESCORT/ORION/ RS TURBO 1.6 1984-92	CB02
FORD PUMA 1.7 16V	CB32
FORD FOCUS 1.6 1.8 2.0 16V	CB28
FORD SIERRA/CORTINA/RS2000 2.0 1977-90	CB03
FORD COSWORTH 16V 1986-93	CB09
FORD 16V ZETEC 1.8 2.0 1992 on	CB10
PEUGEOT 106 16V	CB16
PEUGEOT 205/309 1.6i/1.9i upto 92	CB07
PEUGEOT 205/309 1.6i/1.9i post 92	CB08
PEUGEOT 205/106 1360cc with AC	CB14
PEUGEOT 205/106 1360cc without AC	CB15
PEUGEOT 205 1300 RALLYE	CB26
PEUGEOT 206 GTi 2.0 16V	CB30
PEUGEOT 405/306 16V 2.0 Litre	CB16
PEUGEOT 405 Mi6 1.9 16V	CB31
RENAULT 1.8 16V POST 91	CB20
RENAULT 2.0 16V	CB21
RENAULT 2.0 16V 172HP F4R	CB33
ROVER K SERIES 1.8/1.6/1.4 16V UP TO 1989	CB27
TOYOTA 4AGE 1.6 16V	CB22
VAUXHALL 2.0 16V upto 92	CB11
VAUXHALL ASTRA/NOVA 1.3 1980-93	CB04
VAUXHALL ASTRA/CAVALIER/CALIBRA 1.8 1981-92 2.0 1988 on	CB05
VAUXHALL NOVA/ASTRA 1.4/1.6 upto 91	CB17
VAUXHALL CORSA/ASTRA 1.4/1.6 Post 91	CB18

	PART No.
VAUXHALL CORSA 1.4/1.6 16V	CB19
VW GOLF IV GTi 1.8/1.8 TURBO 20V	CB29
VW GOLF/SCIROCCO/CORRADO 1.6/1.8 8V	CB06
VW GOLF/SCIROCCO/CORRADO 2.0 16V	CB23
VW GOLF/SCIROCCO/CORRADO 1.8 16V	CB24
VW GOLF/SCIROCCO/CORRADO 2.0 8V	CB25



PART NO.	TYPE	INSTALLED HEIGHT	INSTALLED PRESSURE	MINIMUM HEIGHT	MAXIMUM PRESSURE	COIL BIND	I.D	O.D	MAXIMUM LIFT
VS1	DOUBLE	34.0mm	70lbs	20.0mm	240lbs	19.0mm	15.5mm	28.1mm	14.0mm
VS2	DOUBLE	36.0mm	74lbs	20.0mm	200lbs	19.0mm	16.0mm	29.2mm	16.0mm
VS3	DOUBLE	38.0mm	120lbs	26.0mm	260lbs	25.0mm	18.8mm	34.0mm	12.0mm
VS5	SINGLE	32.0mm	80lbs	20.0mm	205lbs	19.0mm	21.0mm	28.5mm	12.0mm
VS7	DOUBLE	34.0mm	65lbs	21.0mm	220lbs	20.0mm	16.5mm	28.8mm	13.0mm
VS9	SINGLE	36.5mm	58lbs	23.0mm	190lbs	22.0mm	23.8mm	32.4mm	13.5mm
VS12	SINGLE	38.8mm	64lbs	23.5mm	225lbs	22.5mm	23.0mm	31.4mm	15.3mm
VS15	DOUBLE	34.0mm	65lbs	21.0mm	220lbs	20.0mm	16.5mm	28.8mm	13.0mm
VS17	DOUBLE	34.0mm	65lbs	21.0mm	220lbs	20.0mm	16.5mm	28.8mm	13.0mm
VS22	SINGLE	37.0mm	104lbs	26.0mm	220lbs	25.0mm	23.6mm	32.5mm	11.0mm
VS25	SINGLE	40.0mm	65lbs	23.0mm	270lbs	22.0mm	25.4mm	34.0mm	17.0mm
VS26	SINGLE	40.0mm	65lbs	23.0mm	270lbs	22.0mm	25.4mm	34.0mm	17.0mm
VS27	DOUBLE	40.0mm	100lbs	26.0mm	260lbs	25.0mm	18.8mm	34.0mm	14.0mm
VS30	SINGLE	32.0mm	68lbs	20.0mm	175lbs	19.0mm	20.7mm	28.1mm	13.0mm
VS31	SINGLE	32.0mm	85lbs	21.0mm	188lbs	20.0mm	21.3mm	28.8mm	11.0mm
VS34	DOUBLE	34.0mm	90lbs	21.0mm	250lbs	20.0mm	16.0mm	28.8mm	13.0mm
VS35	SINGLE	38.0mm	80lbs	25.0mm	205lbs	24.0mm	23.0mm	31.3mm	13.0mm
VS37	SINGLE	38.0mm	64lbs	25.0mm	198lbs	24.0mm	21.3mm	29.1mm	13.0mm
VS38	DOUBLE	34.0mm	70lbs	20.0mm	240lbs	19.0mm	15.5mm	28.1mm	14.0mm
VS39	DOUBLE	34.0mm	90lbs	21.0mm	250lbs	20.0mm	16.0mm	28.8mm	13.0mm
VS41	SINGLE	38.0mm	70lbs	23.5mm	225lbs	22.5mm	23.0mm	31.4mm	14.5mm
VS42	DOUBLE	37.0mm	70lbs	21.0mm	224lbs	20.0mm	17.3mm	30.5mm	16.0mm
VS43	DOUBLE	38.0mm	60lbs	21.0mm	224lbs	20.0mm	17.3mm	30.5mm	17.0mm
VS44	SINGLE	40.0mm	74lbs	25.0mm	205lbs	24.0mm	23.0mm	31.3mm	15.0mm
VS45	DOUBLE	34.0mm	90lbs	21.0mm	250lbs	20.0mm	16.0mm	28.8mm	13.0mm
VS46	SINGLE	37.0mm	48lbs	26.0mm	146lbs	25.0mm	17.6mm	24.9mm	11.0mm
VS48	SINGLE	37.0mm	85lbs	23.5mm	225lbs	22.5mm	23.0mm	31.4mm	13.5mm
VS49	SINGLE	36.0mm	80lbs	24.0mm	140lbs	23.0mm	21.6mm	29.0mm	12.0mm
VS51	SINGLE	37.0mm	70lbs	24.0mm	190lbs	23.0mm	18.2mm	25.6mm	13.0mm
VS52	DOUBLE	37.0mm	100lbs	21.5mm	230lbs	20.5mm	17.4mm	30.5mm	15.5mm
VS54	DOUBLE	38.0mm	140lbs	25.5mm	296lbs	24.5mm	17.3mm	31.1mm	12.5mm
VS55	SINGLE	34.0mm	70lbs	21.0mm	185lbs	20.0mm	21.3mm	28.8mm	13.0mm
VS56	SINGLE	38.0mm	120lbs	23.5mm	230lbs	22.5mm	23.8mm	31.7mm	14.5mm
VS59	DOUBLE	37.0mm	64lbs	23.0mm	210lbs	22.0mm	14.7mm	27.0mm	14.0mm
VS60	SINGLE	38.0mm	56lbs	24.0mm	188lbs	22.5mm	Conical	-	14.0mm

VALVE SPRINGS



VALVE SPRING RETAINERS

ENGINE TYPE	TITANIUM RETAINER PART N°	ALLOY RETAINER PART N°	STEEL RETAINER PART N°
FORD X/FLOW 5/16 VALVE RETAINERS SUITABLE FOR VS1	VRT07-S	VR2	ST17
FORD X/FLOW 9/32 VALVE RETAINERS SUITABLE FOR VS39/VS7	VRT05	VR9	ST33
FORD X/FLOW 5/16 VALVE RETAINERS SUITABLE FOR VS39/VS7	VRT07	VR8	ST17
FORD COSWORTH 16V RETAINERS SUITABLE FOR VS34	VRT02	VR10	ST10
FORD DURATEC I4 16V RETAINERS SUITABLE FOR VS51	VRT24	-	ST40
FORD DURATEC I4 16V RETAINERS SUITABLE FOR VS59	VRT26	-	ST26
FORD FOCUS 2.0 16V OVERSIZE RETAINERS SUITABLE FOR VS51	VRT16	-	-
FORD OHC PINTO RETAINERS SUITABLE FOR VS42	-	VR5	ST5
FORD ZETEC 16V RETAINERS SUITABLE FOR VS46 WITH SINGLE GROOVE VALVE	-	VR14	-
FORD ZETEC 16V RETAINERS SUITABLE FOR VS46 WITH TRIPLE GROOVE VALVE	-	VR19	-
FORD ZETEC RETAINERS SUITABLE FOR USE WITH CF56/VS34 WITH SINGLE GROOVE VALVE	VRT11	-	-
FORD ZETEC RETAINERS SUITABLE FOR USE WITH CF56/VS34 WITH TRIPLE GROOVE VALVE	VRT18	-	-
HONDA 1.6 V/TEC RETAINERS SUITABLE FOR VS34	VRT09	-	-
LOTUS ELISE OVERSIZE RETAINERS SUITABLE FOR VS34	VRT19	-	-
PEUGEOT 106 16V RETAINERS SUITABLE FOR VS51	VRT25	-	ST25
PEUGEOT 405 Mi 16V RETAINERS SUITABLE FOR VS34	VRT12	-	-
PEUGEOT 205 8V RETAINERS SUITABLE FOR VS54	VRT23	-	-
PEUGEOT 306GTi6 16V RETAINERS SUITABLE FOR VS34	VRT15	-	-
RENAULT 1.8/2.0i 16V RETAINERS SUITABLE FOR VS34	VRT03	-	-
ROVER "A" SERIES RETAINERS SUITABLE FOR VS39	VRT06	VR9	ST33
ROVER "A" SERIES RETAINERS SUITABLE FOR VS1	VRT06-S	VR1	ST33
ROVER "B" SERIES RETAINERS SUITABLE FOR VS3/VS27	-	-	ST48
ROVER "K" SERIES RETAINERS SUITABLE FOR VS51	-	-	ST69
ROVER "K" SERIES OVERSIZE RETAINERS SUITABLE FOR VS34	VRT19	-	-
ROVER V8 RETAINERS SUITABLE FOR VS43	-	-	ST47
VAUXHALL 1.3 RETAINERS SUITABLE FOR VS1/VS30/VS31/VS39	-	-	ST30
VAUXHALL 8V 2.0 RETAINERS SUITABLE FOR VS1	-	VR15	-
VAUXHALL ASTRA 16V RETAINERS SUITABLE FOR VS34/VS55	VRT01	VR11	ST55
VAUXHALL CORSA 16V RETAINERS SUITABLE FOR VS34/VS55	VRT08	VR12	ST45
VAUXHALL 2.0 ECOTEC 16V RETAINERS SUITABLE FOR VS34/VS55	VRT21	VR12	ST45
VW 1.8/2.0 8V MECHANICAL RETAINERS SUITABLE FOR VS39	VRT22	-	-
VW 1.8/2.0 TRIPLE GROOVE VALVE 16V RETAINERS SUITABLE FOR VS34	VRT14	-	-
VW 1.8/2.0 SINGLE GROOVE VALVE 16V RETAINERS SUITABLE FOR VS34	VRT27	-	-

VALVE SPRING KITS and CONTENTS

ENGINE TYPE	VALVE SPRING KIT PART N°	RETAINER	SPRING
FORD X/FLOW 9/32 VALVE STEM DIAMETER	VSK05	VRT05	VS39
FORD X/FLOW 9/32 VALVE STEM DIAMETER	VSK35	ST33	VS39
FORD X/FLOW 5/16 VALVE STEM DIAMETER	VSK07	VRT07	VS39
FORD X/FLOW 5/16 VALVE STEM DIAMETER	VSK36	ST17	VS39
FORD COSWORTH 16V	VSK02P	VRT02	VS34
FORD COSWORTH 16V	VSK32P	ST10	VS34
FORD DURATEC I4 16V	VSK24P	VRT26	VS59
FORD DURATEC I4 16V	VSK26P	ST26	VS59
FORD FOCUS 16V 2.0L	VSK16	VRT16	VS51
FORD ZETEC SINGLE GROOVE VALVE	VSK11P	VRT11	VS34
FORD ZETEC TRIPLE GROOVE VALVE	VSK18P	VRT18	VS34
LOTUS ELISE	VSK19P	VRT19	VS34
PEUGEOT 106 16V TU5J4 ENGINE CODE	VSK28	VRT25	VS51
PEUGEOT 106 16V TU5J4 ENGINE CODE	VSK33	ST25	VS51
PEUGEOT 405 MI 16V XU9J4 ENGINE CODE	VSK12P	VRT12	VS34
PEUGEOT 205 8V 8MM VALVE STEM DIAMETER TU3-5 ENGINE CODE	VSK23	VRT23	VS54
PEUGEOT 205/106 8V 7MM VALVE STEM DIAMETER TU3P-5P ENGINE CODE	VSK40P	VRT12	VS39
PEUGEOT 306GTi6 16V XU10J4RS ENGINE CODE	VSK15P	VRT15	VS34
RENAULT 1.8/2.0i 16V F7B/F7R ENGINE CODE	VSK03P	VRT03	VS34
ROVER "K" SERIES	VSK29	ST69	VS51
ROVER "K" SERIES	VSK19P	VRT19	VS34
VAUXHALL NOVA 1.4 1.6 8V POST 89	VSK45P	ST30	VS39
VAUXHALL ASTRA 2.0 8V	VSK43P	VR15	VS1
VAUXHALL 2.0 16V C20XE ENGINE CODE	VSK01P	VRT01	VS34
VAUXHALL 2.0 16V C20XE ENGINE CODE	VSK25P	ST55	VS55
VAUXHALL 2.0 16V C20XE ENGINE CODE	VSK41P	ST55	VS34
VAUXHALL 1.6 16V X16XE ECOTEC ENGINE CODE	VSK08P	VRT08	VS34
VAUXHALL 1.6 16V X16XE ECOTEC ENGINE CODE	VSK27P	ST45	VS55
VAUXHALL 1.6 16V X16XE ECOTEC ENGINE CODE	VSK42P	ST45	VS34
VAUXHALL 2.0 16V X20XE ECOTEC ENGINE CODE	VSK21P	VRT21	VS34
VAUXHALL 2.0 16V X20XE ECOTEC ENGINE CODE	VSK38P	VRT21	VS55
VW 1.8/2.0 8V	VSK22P	VRT22	VS39
VW 1.8/2.0 8V TRIPLE GROOVE VALVE 16V	VSK14P	VRT14	VS34
VW 1.8/2.0 8V SINGLE GROOVE VALVE 16V	VSK37P	VRT27	VS34

CAM FOLLOWERS

	PART No.
ALFA ROMEO	
1800 - 2000 8 Valve TWIN CAM	CF68
AUDI	
80 HYDRAULIC	CF38
BMW	
M40 HYDRAULIC 88 onwards ROCKERS	CF59
M20 6 CYL ROCKERS	CF60
CITROEN	
BX 1.6 1.9 GTi	CF37
SAXO VTS 1.6 16V HYDRAULIC	CF65

	PART No.
FORD	
1600/2000 OHC STANDARD PAD	CF36
1600/2000 OHC SPECIAL PAD	CF12
X/FLOW 109E NARROW STEM	CF76
X/FLOW 711M WIDE STEM	CF77
V6 3000	CF9
V6 3000 GPI FOLLOWER	CF58
V6 2.3/2.8 TAUNUS	CF10
CVH ESCORT SOLID ADJUSTABLE	CF11
CVH ESCORT HYDRAULIC	CF28
RS2000 16V DOHC HYDRAULIC	CF69
COSWORTH STD VALVE, STD BASE CIRCLE SOLID	CF46
COSWORTH STD VALVE, REPROFILED CAMS SOLID	CF47
COSWORTH LONG STEM VALVE SOLID	CF48
COSWORTH HYDRAULIC	CF51
ZETEC HYDRAULIC	CF52
ZETEC SOLID STANDARD SIZE	CF57
ZETEC SOLID OVERSIZE 32mm	CF56
FOCUS SOLID STANDARD SIZE	CF66
KA 1.3 and 1.1/1.3 HCS	CF49
LOTUS	
LOTUS TWIN CAM	CF40
LOTUS 912/907 16 VALVE	CF97

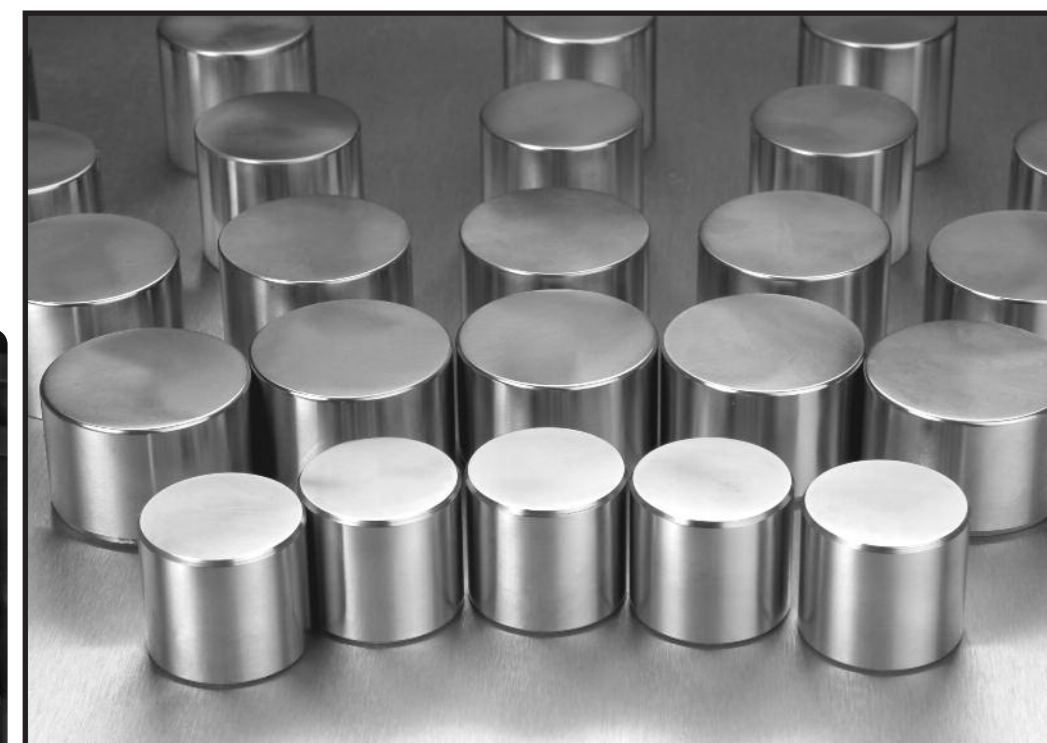

CAM FOLLOWERS

	PART No.
PEUGEOT	
205/306 1.6/1.9 GTI/2.0 XSI	CF37
306/405 16 VALVE SOLID	CF43
306/405 16 VALVE HYDRAULIC	CF55
306 16 VALVE 6 SPEED GTi6 HYDRAULIC	CF64
106 16 VALVE HYDRAULIC	CF65
106 16 VALVE SOLID Standard Diameter	CF93
106 16 VALVE SOLID Oversize 30mm Diameter	CF66
RENAULT	
CLIO 16 VALVE HYDRAULIC	CF53
CLIO 16 VALVE SOLID	CF44
ROVER	
V8 HYDRAULIC	CF22
V8 SOLID	CF23
A SERIES	CF1
B SERIES LATE TYPE	CF94
A SERIES CROSS-DRILLED LIGHTWEIGHT	CF95
MGB EARLY PRE 1971	CF4
K SERIES 16 VALVE SOLID	CF45
K SERIES 16 VALVE HYDRAULIC	CF63
SEAT	
2.0 LITRE 8 VALVE CUPRA SPORT/TOLEDO	CF38
2.0 LITRE 16 VALVE IBIZA/CORDOBA/TOLEDO	CF62
TOYOTA	
COROLLA/MR2/4AGE COMPETITION FOLLOWER	CF70
TRIUMPH	
1300/1500	CF24
2000/2.5PI	CF25

	PART No.
VAUXHALL	
MANTA/CAVALIER 1600/1900/2000 RWD CIH HEAD SOLID	CF21
ASTRA/CALIBRA/CORSA/NOVA 1.3/1.4/1.6/1.8/2.0 8V FWD <small>To be used with S36 & Hydraulic Cams</small>	CF20
ASTRA/CALIBRA/CORSA 16 VALVE SOLID	CF41
ASTRA/CALIBRA/CORSA 16 VALVE HYDRAULIC	CF54
VW	
GOLF 8 VALVE HYDRAULIC	CF38
GOLF 16 VALVE SOLID	CF42
GOLF 16 VALVE HYDRAULIC	CF62
GOLF VR6 HYDRAULIC	CF67
GOLF 8 VALVE MECHANICAL COMPETITION FOLLOWER	CF71

SHIM KITS

PART No.	INTERNAL DIAMETER	INTERNAL DEPTH	EXTERNAL DIAMETER	SHIM THICKNESS
S67-5.50	5.5MM	3.3MM	10MM	5MM
S67-6.00	6MM	2.5MM	10MM	5MM
S67-7.00	7MM	2.5MM	10MM	5MM
S67-9.32	9/32"	2.5MM	10MM	5MM
S67-8.00	8MM	2.5MM	10MM	5MM

OIL PUMPS

OIL PUMPS

	PART No.
ROVER	
“A” SERIES PIN DRIVE Std Pressure	OP1
“A” SERIES STAR DRIVE Std Pressure	OP2
“A” SERIES METRO Std Pressure	OP3
“A” SERIES METRO 3 Bolt Std Pressure	OP13
FORD	
1600/2000 OHC PINTO HIGH PRESSURE	OP8
1600/2000 OHC PINTO HIGH PRESSURE/HIGH CAPACITY	OP9
X/FLOW - LOTUS T/C HIGH PRESSURE	OP4
X/FLOW - LOTUS T/C HIGH PRESSURE/HIGH CAPACITY	OP5
FIESTA HIGH PRESSURE	OP6
V6/V4 UK HIGH PRESSURE LATE TYPE	OP10

VALVE STEM OIL SEALS

	PART No.
FORD PINTO FOR USE IN ENGINES WHERE VALVE LIFT EXCEEDS .430"/10.92mm	S49
FORD X/FLOW FOR USE WITH DOUBLE VALVE SPRING ASSEMBLIES	S37
FORD CVH FOR USE WITH DOUBLE VALVE SPRINGS	S71
FORD ZETEC FOR USE WITH VG16	S38

BRONZE VALVE GUIDES

	O.A.L.	EXTERNAL DIAMETER	INTERNAL DIAMETER	PART No.
FORD BDA INLET	1.557"	0.472"	9/32"	VG07
FORD BDA EXHAUST	1.465"	0.473"	9/32"	VG08
FORD BDG INLET	1.537"	0.512"	9/32"	VG09
FORD COSWORTH INLET	43mm	13mm	7mm	VG05
FORD COSWORTH EXHAUST	43mm	13mm	8mm	VG06
FORD DURATEC	37mm	11mm	5.5mm	VG18
FORD PINTO	51mm	12.7mm	8mm	VG04
FORD X/FLOW	2.000"	0.501"	5/16"	VG03
FORD ZETEC	36mm	12mm	6mm	VG16
ROVER “A” SERIES	1.645"	0.471"	9/32"	VG01
VAUXHALL ASTRA 16V	45mm	11mm	7mm	VG15

MISCELLANEOUS

	PART No.
FORD COSWORTH YB ACCESSORIES	
FORD COSWORTH Alloy Jackshaft	CA99
FORD COSWORTH 4wd to 2wd cam spacers	S4
FORD COSWORTH steel crank pulley	S84
FORD OHC ACCESSORIES	
FORD O.H.C spray bars	S7
FORD O.H.C. extra long ball stud	S62
FORD O.H.C. uprated follower retaining clips	S81
FORD O.H.C. alloy jackshaft	CA75
FORD X-FLOW ACCESSORIES	
FORD X-FLOW double width tensioner pad	S70
FORD X-FLOW duplex chain	S46
FORD X-FLOW off set dowel kit	S10
FORD X-FLOW Bronze gears	S6
FORD X-FLOW 100mm crank v belt pulley	S5
FORD X-FLOW non adjustable duplex kit	S8
FORD X-FLOW rocker posts std length	S2
FORD X-FLOW rocker spacer set	S16
FORD X-FLOW rocker shaft	S34
LOTUS ACCESSORIES	
LOTUS 912 non adj pulley round tooth	CA98
LOTUS 912 crank pulley round tooth	S82
LOTUS 912 eccentric	S83
ROVER ACCESSORIES	
B.L.M.C. ‘A’ SERIES duplex chain	S52
ROVER V8 duplex chain	S54
VAUXHALL ACCESSORIES	
ASTRA competition lash caps	S64
ASTRA adj ball studs	S36
LUBES AND TIMING ACCESSORIES	
CAM LUBE per bottle 250ml	BL
CAMSHAFT TIMING DISC	S26



COMETIC GASKET APPLICATION	PART NO	BORE	THICKNESS
BMW MINI	C4308-027	78.5mm	.027"
COSWORTH BDG	C4494-040	91.0mm	.040"
COSWORTH BDG	C4494-051	91.0mm	.051"
COSWORTH FVA-FVC	C4138-040	87.0mm	.040"
COSWORTH FVA-FVC	C4135-040	88.0mm	.040"
FORD BDA X-FLOW-LOTUS T/C	C4102-040	82.0mm	.040"
FORD BDA X-FLOW-LOTUS T/C	C4103-040	83.0mm	.040"
FORD BDA X-FLOW-LOTUS T/C	C4140-040	84.0mm	.040"
FORD BDA X-FLOW-LOTUS T/C	C4133-040	85.0mm	.040"
FORD BDA X-FLOW-LOTUS T/C	C4142-040	86.0mm	.040"
FORD BDA X-FLOW-LOTUS T/C	C4143-040	87.0mm	.040"
FORD CVH 1.6 Ltr	C5756-051	83.0mm	.051"
FORD PINTO 2.0 Ltr	C4350-040	92.5mm	.040"
FORD PINTO 2.0 Ltr	H1267SP1040S	94.5mm	.040"
FORD ZETEC /FOCUS 2.0 Ltr	C4279-027	87.0mm	.027"
FORD COSWORTH YB	C4350-051	92.5mm	.051"
FORD COSWORTH YB 5 Layer	C4350-070	92.5mm	.070"
FORD DURATEC	H2389030S	90.0mm	.030"
FORD DURATEC 12mm Stud Hole	H2264SP6030S	90.0mm	.030"
LOTUS T/C Non Embossed C/T	H0464SP5040XP	84.0mm	.040"
JAGUAR 4.2L 6CYL	C4127-040	93.7mm	.040"
JAGUAR 3.4L 6CYL	C4303-040	85.0mm	.040"
JAGUAR 3.8L 6CYL	C4306-040	89.0mm	.040"
JAGUAR 3.8L 6CYL	C4306-051	89.0mm	.051"
MAZDA 323 16V	C4481-030	89.0mm	.030"
NISSAN GTiR 1990-1994	C4156-051	86.0mm	.051"
NISSAN GTiR 1990-1994	C4543-040	87.5mm	.040"
NISSAN SR20	C4130-040	88.5mm	.040"

COMETIC GASKET APPLICATION continued	PART NO	BORE	THICKNESS
OPEL MANTA CIH	C4512-051	97.0mm	.051"
PEUGEOT 106 16V	C4493-060	79.0mm	.060"
PEUGEOT Mi16 16V	C4225-051	84.0mm	.051"
PORSCHE 996 3.6LTR	C4492-040	102.0mm	.040"
ROVER A SERIES	C4146-030	73.0mm	.030"
ROVER A SERIES	H0525SPA040S	72.5mm	.040"
ROVER A SERIES	C4146-040	73.0mm	.040"
ROVER A SERIES	H0525SP3040S	73.5mm	.040"
ROVER A SERIES	C4148-040	74.0mm	.040"
ROVER B SERIES	C4147-040	83.0mm	.040"
ROVER V8	C4367-040	89.0mm	.040"
SUBARU IMPREZA Sti 04-08	C4264-040	100.00mm	.040"
SUBARU EJ 20	C4261-045	93.0mm	.045"
SUBARU EJ 25	C4263-051	98.0mm	.051"
TVR SPEED 6	C4527-060	96.5mm	.060"
TOYOTA 4AGE 1.6 16V	C4170-040	81.0mm	.040"
TOYOTA 3SGE 2.0 16V	C4314-040	87.0mm	.040"
VAUXHALL ECOTEC X20XE	C5768-040	87.0mm	.040"
VAUXHALL C20XE	C4216-051	88.0mm	.051"
VAUXHALL C20XE 5 Layer	C4216-070	88.0mm	.070"
VAUXHALL ECOTEC X16XE	C4257-051	82.0mm	.051"
VW 1.8 Ltr 8 Valve - 16 Valve	C4247-051	83.0mm	.051"
VW 2.0 Ltr 8 Valve -16 Valve	C4246-051	85.0mm	.051"
VW 2.0Ltr 20 Valve 4 Cyl	C4541-051	83.5mm	.051"
VOLVO B23	C4499-045	97.0mm	.045"
VOLVO B18A/B/D	C4287-045	86.0mm	.045"
VOLVO B20A	C4289-045	92.0mm	.045"

CONROD BOLTS	PART N°	LBS/FT with ARP ULTRA LUBE	ARP STRETCH with ULTRA LUBE
ALFA ROMEO 2.0 GTV	BEB49-8	45	0.0075" - 0.0080"
FORD X/FLOW STEEL RODS 3/8" 220,000 PSI 12 POINT 1.5" UHL	BEB08-8	55	0.0055" - 0.0060"
FORD X/FLOW 1300/1600 3/8" 220,000 PSI 12 POINT 1.75" UHL	BEB09-8	55	0.0065" - 0.0070"
FORD COSWORTH/SIERRA/ESCORT 3/8" 12 POINT GP 'A'	BEB19-8	45	0.0065" - 0.0070"
FORD 2.0L/1.8L/1.6L ZETEC 190,000 PSI 1.8" UHL	BEB17-8	25	0.0050" - 0.0055"
FORD V6 2.8L & 2.9L 5/16" 12 POINT	BEB16-12	35	0.0060" - 0.0065"
FORD V6 3000	BEB51-12	50	0.0050" - 0.0055"
FORD CVH 1.9L	BEB48-8	28	0.0060" - 0.0065"
FORD CVH 190,000 PSI 1.7" UHL	BEB22-8	25	0.0055" - 0.0060"
FORD PINTO 2.0L 190,000 PSI	BEB60-8	40	0.0060" - 0.0065"
FORD FOCUS 2.0 16V	BEB36-8	25	0.0050" - 0.0055"
FORD FOCUS ST170 2.0 16V	BEB62-8	36	0.0045" - 0.0050"
FORD I4 DURATEC 16V	BEB46-8	45	0.0065" - 0.0070"
FORD GENERAL REPLACEMENT 1.5 UHL 5/16"	BEB28-8	30	0.0050" - 0.0055"
FORD GENERAL REPLACEMENT 1.6 UHL 3/8"	BEB57-8	55	0.0055" - 0.0060"
HONDA K20A 16V	BEB55-8	50	0.0080" - 0.0085"
HONDA 1.2L - 1.6L 8mm	BEB41-8	26	0.0050" - 0.0055"
HONDA 1.8L	BEB44-8	50	0.0070" - 0.0075"
LOTUS 8V TWIN CAM 3/8" 220,000 PSI 12 POINT 1.75" UHL	BEB09-8	55	0.0065" - 0.0070"
MINI ONE-COOPER-'S' 1.6 16V	BEB47-8	25	0.0055" - 0.0060"
MINI ONE-COOPER-'S' 1.6 16V	BEB31-8	26	0.0060" - 0.0065"
NISSAN 2.0 16V	BEB32-8	45	0.0065" - 0.0070"
PEUGEOT 205/309 8V 405-306 16V	BEB25-8	45	0.0070" - 0.0075"
PORSCHE 911 9mm TYPE	BEB52-12	40	0.0100" - 0.0105"
PORSCHE 911 10mm TYPE	BEB53-12	50	0.0095" - 0.0100"
RENAULT CLIO 16s - MEGANE 16s	BEB26-8	42	0.0065" - 0.0070"
ROVER 'A' SERIES 850/1098 3/8" 220,000 PSI 12 POINT 1.5 UHL	BEB08-8	55	0.0055" - 0.0060"
ROVER 'A' SERIES 1300 11/32"	BEB1-8	35	0.0065" - 0.0070"
ROVER 'A' SERIES 1275 MIDGET AND COOPER 'S'	BEB6001-8	55	0.0065" - 0.0070"
ROVER 'B' SERIES LATE 18V MGB 11/32"	BEB1-8	35	0.0065" - 0.0070"
ROVER 'B' SERIES DIAGONAL SPLIT MGB RODS 3/8" X 2.0"	BEB12-8	45	0.0065" - 0.0070"
ROVER 'K' SERIES	BEB37-8	30	0.0045" - 0.0050"

CONROD BOLTS - FLYWHEEL BOLTS

CONROD BOLTS continued	PART N°	LBS/FT with ARP ULTRA LUBE	ARP STRETCH with ULTRA LUBE
ROVER V8 3500 190,000 PSI	BEBRV60-16	45	0.0050" - 0.0055"
TOYOTA 4AGE 1.6 16V	BEB27-8	40	0.0050" - 0.0055"
TOYOTA 3SGTE	BEB50-8	50	0.0060" - 0.0065"
TOYOTA SUPRA 2JZ	BEB54-12	65	0.0075" - 0.0080"
TRIUMPH 1300 - 1500 SPITFIRE 3/8" 1.7" UHL	BEB15-8	45	0.0065" - 0.0070"
TRIUMPH GT6 - TR6 3/8" 1.7" UHL	BEB15-12	45	0.0065" - 0.0070"
TRIUMPH TR2/3/4 7/16" 220,000 PSI 1.8" UHL	BEB20-8	75	0.0055" - 0.0060"
VAUXHALL 2.0L 16V 190,000 PSI 9mm	BEB18-8	32	0.0055" - 0.0060"
VAUXHALL 1300 190,000 PSI 1.8" UHL 8mm x 1.0	BEB23-8	25	0.0050" - 0.0055"
VAUXHALL 1.4/1.6 8V - 16V 190,000 PSI 8mm x 1.25	BEB24-8	24	0.0050" - 0.0055"
VAUXHALL 1.4/1.6/1.8 9mm x 1.25 Post 98	BEB56-8	32	0.0050" - 0.0055"
VW 1.6 1.8 2.0 LATE 8MM TYPE	BEB34-8	35	0.0085" - 0.0090"
VW 1.6 1.8 2.0 EARLY 9MM TYPE	BEB35-8	40	0.0065" - 0.0070"
VW VR6	BEB39-12	40	0.0075" - 0.0080"

FLY WHEEL BOLTS	PART N°	LBS/FT with ARP ULTRA LUBE
ROVER 'A' SERIES 948 - 1098 3/8" UNF 0.900" UHL IN LINE ENGINE ONLY	FB900-4	40
ROVER 'A' SERIES 1300 3/8" UNF 0.900" UHL IN LINE ENGINE ONLY	FB900-6	40
ROVER 'B' SERIES - MGB 18V 12 POINT	FBB716-6	65
FORD X/FLOW 1300 - 1600 3/8" UNF 0.900" UHL	FB900-6	40
FORD PINTO 2.0L 10mm 12 POINT	FB1150-6	52
FORD COSWORTH/SIERRA/ESCORT 10mm 12 POINT	FB1150-9	52
FORD ZETEC 16V	FBFZ01	70
FORD I4 DURATEC 16V	FBFD02	85
FORD I4 DURATEC 16V CRANK BOLT	CBFD01	145
ROVER 'K' SERIES 16V	FBKS03	58
TOYOTA 4AGE M10x1.25	FBT2802	70
TOYOTA 3SGTE M12x1.25	FBT2801	90
TRIUMPH 1300 - 1500 7/16" X1" UHL 12 POINT	FBT716-4	65

FLYWHEEL BOLTS - HEAD STUD KITS

FLY WHEEL BOLTS continued	PART N°	LBS/FT with ARP ULTRA LUBE
VAUXHALL 1.4 1.6L 16V	FBV826-6	40
VAUXHALL 2.0L 8V 12 POINT FOR STD AND RACE FLY WHEEL	FBV985-6	63
VAUXHALL 2.0L 16V 12 POINT FOR STD AND RACE FLY WHEEL	FBV985-8	63
HEAD STUD KITS	PART N°	LBS/FT with ARP ULTRA LUBE
BMW MINI	HSEBMW4301	65
FORD COSWORTH BDA (4.65 OAL)	HSC48	80
FORD COSWORTH/SIERRA/ESCORT WAISTED STUDS	HSCSW53	90
FORD 1.6 CVH	HSCVH16	60
FORD V6 3.0L ESSEX (12 POINT)	HSF38	110
FORD X/FLOW (12 POINT)	HSFX48	80
FORD 2.0L PINTO (12 POINT)	HSP4201	90
FORD 2.0/1.8/1.6L ZETEC	HSFX02	60
FORD DURATEC 16V	HSFD04	60
FORD DURATEC V6	HSFD4701	60
FORD 1.6 SIGMA VCT 16V	HSFSV65	60
HONDA V-TEC 1.6	HSVT01	80
HONDA ACURA K20A	HSHON4701	80
LOTUS TWIN CAM (12 POINT)	HSL68	80
MGC CAST IRON CYLINDER HEAD	HSMGC2	63
MINI COOPER 1.6	HSMT4203	80
NISSAN SR20 11MM	HSNS4701	85
NISSAN GTIR 12MM	HSNS4303	100
NISSAN SKYLINE GTR	HSNS4207	105
PEUGEOT 106 16V	HSPT106	60
RENAULT 2.0 LTR 16V F4R ENGINE	HSRN4301	105
ROVER 'A' SERIES 11 STUD AND ROCKER STUDS	HSA11	45/28
ROVER 'A' SERIES 11 STUD WITH FRONT BOLT AND ROCKER STUDS	HSA11-B	45/28
ROVER 'A' SERIES 11 STUD AND ROCKER STUDS FOR SHAVED HEAD	HSA11-S	45/28
ROVER 'A' SERIES 9 STUD AND ROCKER STUDS	HSA9	45/28
ROVER 'B' SERIES & ROCKER STUDS	HSB42	45/28
ROVER V8 12 POINT	HSRV45	80
ROVER 'K' SERIES	HSRK4209	50
SUBARU EJ2.0 - EJ2.5	HSSU01	90
SUZUKI GSXR1300 HAYABUSA	HSSUZ4701	60

HEAD STUD KITS - MAIN STUD KITS

HEAD STUD KITS continued	PART N°	LBS/FT with ARP ULTRA LUBE
TOYOTA 4 AGE 16VALVE - MR2 12 POINT	HST4201	60
TOYOTA 3SGTE	HST4204	60
TOYOTA SUPRA 2JZ	HST4205	80
TRIUMPH GT6 (TR6 OK to 3.41" Thickness)	HSGT6	80
TRIUMPH 1300 & 1500 SPITFIRE 10 STUD	HST425-10	45
TRIUMPH TR4	HSTR4	110
VAUXHALL 2.0L 16V 12 POINT NUTS	HSV4301	80
VAUXHALL NOVA/CORSA 8V	HSV2084	60
VAUXHALL CORSA 16V	HSCOR16V	55
VOLKSWAGEN GOLF/SCIROCCO GTi 8VALVE 12 POINT NUTS (4203)	HSVW4703	80
VOLKSWAGEN 1600 AIR COOLED 12 POINT NUTS (4202)	HSVW4201	80
VOLKSWAGEN 1.8/2.0 16V 12 POINT NUTS V/CUT STUDS	HSVW4702	80
VOLKSWAGEN VR6	HSVW4705	80
VOLKSWAGEN 20V M10 inc installation tool	HSVW3902	45+90°

MAIN STUD KITS	PART N°	LBS/FT with ARP ULTRA LUBE
FORD X/FLOW 3.75" OAL STUD 12 POINT NUTS	MSF375	80
FORD V6 3.0L ESSEX 12 POINT NUTS	MSF40	80
FORD 2.0L PINTO METRIC 12 POINT NUTS	MSF54	90
FORD V6 2.8L METRIC	MSF64	90
FORD V6 2.9L METRIC	MSF64117	90
FORD 2.0/1.8/1.6L ZETEC 'E' 16V PRE 5/98 SILVER TOP ENGINE	MSFZ04	80
FORD 2.0/1.8/1.6L ZETEC 'E' 16V POST 5/98 BLACK TOP ENGINE	MSF5404	80
FORD DURATEC 16V	MSFD03	60
FORD 1.6 SIGMA VCT 16V	MSFSV45	60
MITSUBISHI EVO4,5,6	MSMT5402	60
RENAULT 2.0 LTR 16V F4R ENGINE	MSRN5401	60
ROVER 'A' SERIES 1098 2" MAINS & COOPER 'S' (SHOULDERED)	MSA33	80
ROVER 'A' SERIES 1275 (DO NOT USE WASHERS ON MINI)	MSA54	80
ROVER 'B' SERIES 5 MAIN (USE ONLY TO REPLACE STUDS)	MS5B54	110
ROVER V8 12 POINT NUTS	MSRV54	110
SUZUKI GSXR1300 HAYABUSA	MSSUZ5401	20 OEM LOAD
TOYOTA 3SGTE	MST5404	60
TOYOTA 4AGE	MST5403	60
TRIUMPH 1300 & 1500 LARGE MAIN ENGINE	MST54	80
VAUXHALL 2.0L 16VALVE	MSV5401	60
VOLKSWAGEN GOLF/SCIROCCO GTi 8VALVE	MSVW5402	60



MANIFOLD STUD KITS	PART N°
ROVER 'A' SERIES	AMS1
THERMOSTAT HOUSING STUD KIT	PART N°
ROVER 'A' SERIES	THS1
ARP ACCESSORIES	PART N°
ASSEMBLY LUBRICANT 0.5 FL OZ	100-9908
ASSEMBLY LUBRICANT 10 FL OZ	100-9910
3/8 ID 0.675 OD WASHER	200-8506
5/16 ID 0.550 OD WASHER	200-8593
7/16 ID 3/4 OD WASHER	200-8511
7/16 ID 13/16 OD WASHER	200-8510
7/16.20 POINT NUT	300-8303
3/8.24 POINT NUT	300-8302
5/16.24 POINT NUT	300-8301
M8 X 1.25mm 12 POINT NUT	300-8310
M10 X 1.25mm 12 POINT NUT	300-8344
M12 X 1.25mm 12 POINT NUT	300-8307
M12 X 1.75mm 12 POINT NUT	300-8376
8mm ID 14.6mm O.D WASHER	200-8641
10mm ID 19.0mm O.D WASHER	200-8519
12mm ID 2.2mm O.D WASHER	200-8500



ARP INFORMATION

Always wash the fasteners with cleaning solvent prior to installation. They come coated with a "protective" coating, this is NOT a lubricant. Choose correct torque from the chart supplied with the parts. Note the difference in torque settings depending on the thread lubricant used. The torque figures shown will give a preload equal to 75% of the yield strength of the fastener. Use a generous chamfer on all stud holes. Screw studs into the block using 4 ft lbs only. (Basically hand tight). If you feel you have to use a thread locking compound, then be sure to do the final torque before the compound sets. We do not recommend the use of lock tabs which are made from too soft a material, and as it squeezes out, the fastener preload is lost. Due to leverage differences a fine thread will produce a greater preload for a given torque than will a coarse thread of the same diameter. Tap all female threads before installing bolts or studs. (Best not to use a new tap). ARP Ultra Lube part No. 100-9908 is recommended, as its superior lubricating properties produce the correct clamping preload for less torque. For all connecting rods check that the chamfer required to clear the bolt under head radius is adequate and that the bolt passes through the end cap freely - this is VERY important.

PERFORMANCE COMPONENTS

PERFORMANCE COMPONENTS

BIKES

CAM TIMING - The easiest way of timing camshafts is by using the lobe centre angle (L.C.A.) method. This involves setting the engine on true T.D.C. which makes the full lift position for No. 1 inlet, the L.C.A. after T.D.C. and on No. 1 exhaust the L.C.A., before T.D.C. there will be a dwell on full lift. The true position is in the centre of this dwell.

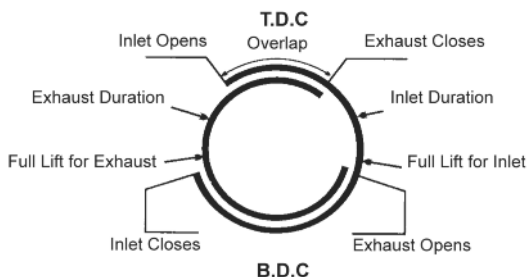

DURATION - The duration quoted is checked with zero valve clearance and 0.040" of lift.

VALVE CLEARANCE ADJUSTMENT - Reprofilng of the camshaft could cause it to come out of the standard shim/adjuster range and oversize shim/adjusters would need to be manufactured.

VALVE - PISTON CLEARANCE - We recommend this should be checked.

On 4 cyl. engines the inlet should have .050" clearance @ 10° after T.D.C. and the exhaust .065" clearance @ 10° before T.D.C. On single cylinder engines the inlet should have .080" clearance @ 12° after T.D.C. and the exhaust .080" clearance @ 12° before T.D.C.

VALVE SPRING & GUIDE CLEARANCE - Valve spring clearance should be a minimum of .040" before coil bind. Valve cap to valve guide clearance should also be a minimum of .040".

ROCKER ARM & CAM FOLLOWERS - It is absolutely essential to use NEW cam followers or rocker arms when installing a new or reconditioned camshaft.

RUNNING IN - After installing the new camshaft ensure that it rotates freely and there is no interference with the cam and followers, on initial start up. Do not allow your engine to idle below 2500 rpm for the first 20 minutes. This should ensure adequate lubrication of cam and followers.

CARS

The installation and first few moments of running are critical factors in the life of the camshaft and the following instructions have been devised in order to obtain maximum performance from the engine and to ensure a long and trouble free life from both the cam and associated components.

1. Before fitting the camshaft check that it is identical in every respect (EXCEPT FOR LOBE PROFILES) to the one being replaced. Special attention should be given to the oil feed details and journal diameters as variations may occur during the manufacture of the engine.
2. On the Vauxhall front wheel drive camshafts - a ball bearing is supplied loose with the camshaft. Please check the original camshaft to see if the ball is fitted into the distributor end main oil gallery. If so fit supplied ball as original Vauxhall cam.
3. Liberally coat both the camshaft and cam followers with cam lube before installation. Failure to do so can cause scuffing between the surface of the cam and the cam followers which will cause premature wear.
4. It is essential that NEW Kent Cam followers are fitted.
5. Upon installation valve springs must be checked to ensure that coil binding does not exist at full lift. There must be a minimum clearance of .040" (1mm) between the centre coils. (Fig 1)

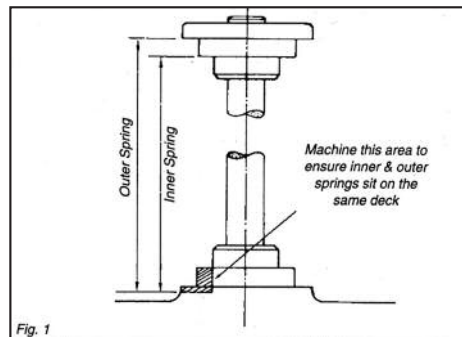

6. When using KENT valve springs ensure that they are fitted as per instructions with the correct installed height. In some instances the cylinder head will need machining. (Fig 1)

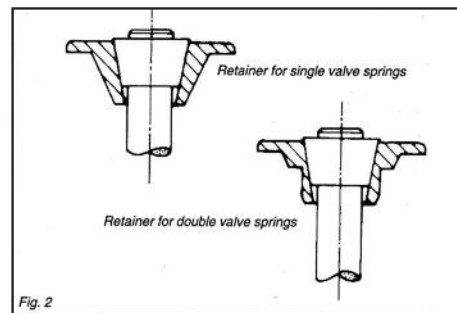

7. When Double springs are being installed in place of singles, the valve spring retainer cap must be machined to accept the inner spring (See Fig 2). Alternatively in most instances we are able to supply modified caps in steel or lightweight alloy.

8. Once the valve springs have been installed check both inner and outer springs for coil binding and ensure that the bottom face of the spring retaining cap does not contact the top of the valve guide or valve stem oil seal. Minimum clearance on full lift is .060" (1.5mm). If this clearance cannot be achieved the top of the guides must be machined. Special stem seals are also available.

9. Certain engines are designed with hydraulic pedestals to pivot the cam followers. The pedestals must be bled of oil and inspected before refitting. If the condition of the pedestals is in any doubt they must be replaced.

10. Having timed in the camshaft check that there is no valve to piston contact - minimum clearance .060" (1.5mm). In twin cam applications ensure there is no valve to valve contact.

11. When modifying engines that utilize finger followers i.e. Ford Pinto SOHC, it is imperative that you ensure the followers remain in the original attitude relative to the cylinder head

(See Fig 3). Failure to do so will alter the rocker geometry, increasing or decreasing valve lift and can result in failure of both cam and followers.

12. When replacing the camshaft ensure only high quality engine oil is used (check that it is the correct grade) and the oil filter is replaced.

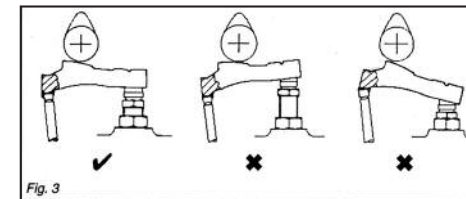

13. Before starting the engine, turn over the engine by hand to ensure that it rotates freely, prime the oil system, and check that everything is set to ensure the engine starts straight away. Do not turn over for any length of time on the starter.

14. Once the engine is running do not allow it to idle for the first twenty minutes, and keep the revs to a minimum of 2500 in order to ensure adequate lubrication of cam and followers.

15. IMPORTANT - TECHNICAL INFORMATION FORD CVH ENGINES - OVERSIZE CAMSHAFTS & FOLLOWERS

Although the vast majority of Ford CVH Engines are fitted with standard size Camshafts & Cam Followers, there are some engines in service which are fitted with Oversizes on these components. Extreme care should be taken to ensure that the correct parts are fitted. Should a Standard Camshaft or Cam Follower be fitted to an Oversize Housing the result will be a very noisy engine. To identify cylinder heads fitted with Oversize Components, Ford stamp the Rocker cover Rail above No. 1 exhaust port with one of the following codes:

- T25 = 0.25mm Oversize Follower - Standard size Camshaft
- C38 = Standard Size Follower - 0.38mm Oversize Camshaft
- C38/T25 = 0.25mm Oversize Follower - Standard size Camshaft

Camshaft timing instructions

There are a number of different methods of cam timing procedure. We at Kent Cams use and recommend either of the following two methods:



CAM TIMING USING LIFT AT TOP DEAD CENTRE METHOD:

In recent years with the proliferation of multi valve and multi cam engines this method has proved extremely popular. The process involves setting your camshafts at a specified lift at TDC.

This Method has been in use by Kent Cams and many top engine builders for many years. The relative simplicity has the benefit of setting individual cams at the same position without resorting to excessive crankshaft rotation:

Refer to the Kent Cams catalogue or web site for the TDC lift figure of your particular camshaft.

1. Set your engine to TDC number 1 cylinder (fig a) it is important to ensure you are in the middle of the dwell which occurs a TDC.
2. Position a clock gauge on the inlet follower and turn the cam to achieve the specified lift (e.g. 2.72mm fig b).
3. If your engine has separate inlet and exhaust cams then position clock gauge on the exhaust follower and set this to its specified lift (e.g. 2.41mm fig c).

With your cams set to their specific Top dead centre lifts it is now time to fit your cam belt or chain, inevitably there will be some movement from the ideal TDC lift figure hence the necessity to check your figures a second time with the belt/chain installed and tensioned. Fine adjustments can then be carried out with the aid of a vernier cam gear / cam pulley.

It is imperative that the engine should be checked to ensure there is no piston to valve contact prior to initial starting.

CAM TIMING USING FULL LIFT BEFORE/AFTER TOP DEAD CENTRE METHOD:

For many years the most commonly used method has involved establishing top dead center (TDC) as a datum (zero degrees) and positioning your camshaft with the inlet or exhaust valve at maximum lift at a given position relative to this datum:

For example take our Ford 2Ltr SOHC camshaft number RL30 which has a quoted figure of inlet timing @ full lift = 105 degrees. This means that the inlet valve should be set to be fully open at 105 degrees after top dead center. Therefore using a protractor or timing disc you can establish 105 degrees after TDC and it is at this point that your inlet valve should be at maximum lift. Minor adjustments from the standard timing point can be made with the aid of an adjustable timing gear.

1. Zero a timing disc on your crankshaft with the engine set at top dead centre (fig a)
2. Rotate crankshaft in direction of normal rotation (after TDC) to the specified Full lift position as quoted in the Kent Cams catalogue or web site. (fig d. 105 degrees).
3. Establish, with the aid of a clock gauge, that the inlet valve has achieved maximum lift and is in the middle of its dwell period.
4. Adjustments on the cam pulley can then be made to achieve this.
5. If your engine has a separate exhaust camshaft then return to top dead centre and rotate the crankshaft to the quoted full lift position before top dead centre (opposite direction of rotation. fig e.). It is at this point your exhaust valve should have reached maximum lift. Once again fine adjustments can be made on the cam pulley

It is imperative that the engine should be checked to ensure there is no piston to valve contact prior to initial starting.



A



B

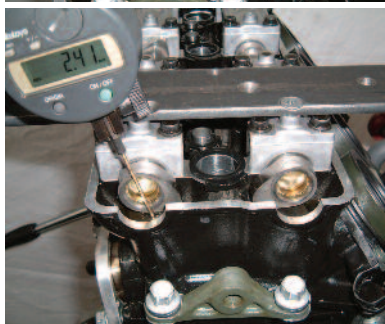

C



D



E



www.kentcams.com

Kent Performance Cams Ltd.

Units 1-7 Military Road, Shorncliffe Industrial Estate, Folkestone, Kent CT20 3UJ

Tel: +44 (0) 1303 248666 Fax: +44 (0) 1303 252508 Email: info@kentcams.com